

## A Novel Configuration for Voltage Sharing in DC-DC Converters

A. Nami<sup>1</sup>, A. A. Boora<sup>1</sup>, F. Zare<sup>1</sup>, A. Ghosh<sup>1</sup>, F. Blaabjerg<sup>2</sup>

<sup>1</sup>School of Electrical Engineering Queensland University of Technology GPO Box 2434, Brisbane, QLD, 4001, Australia E-mail: [namia@qut.edu.au](mailto:namia@qut.edu.au)

<sup>2</sup>Aalborg University, Institute of Energy Technology, 9220 Alborg East, Denmark [fbl@iet.aau.dk](mailto:fbl@iet.aau.dk)

**Abstract.** This paper presents a new multi-output voltage sharing (MOVS) converter. A high voltage application has been considered in this paper, where a novel DC-DC converter is being used as interface in high power renewable energy systems based on diode-clamped multilevel inverter, in which high quality regulated DC voltage is generated for DC link capacitors. Different output voltage sharing can be achieved by a given duty cycle for low and high power applications. Meanwhile, capacitor unbalancing problem in diode-clamped converters could be avoided as the voltage across each capacitor is controlled to the desired voltage level which decreases in complexity of inverter control. The topology easily can be extended to give multiple outputs. In order to verify the proposed topology, steady state and dynamic analysis have been studied. Simulation results are presented to show the operation of the proposed converters.

### Key words

DC-DC converters, multi-output converter, diode-clamped topology

### 1. Introduction

DC-DC converters are widely used in low and high power applications [1]. Multi-output DC-DC converters are more efficient compared to use several separate single output power supplies [2]. Conventional multi-output DC-DC converters utilize a transformer with multiple secondary winding to deliver power into the different outputs [3]. Recently, multi-output converters are employed with multiple inductors, in which, for  $M$  output voltages,  $M$  inductors are required. As the number of output voltages increase, the number of required inductors will be increased which leads to an increase of the cost and size of the system. Single inductor in the configuration of multi-output DC-DC converters can decrease losses substantially as well as decoupling losses between parallel inductors [4]. Multi-output voltage sharing DC-DC converters with a single inductor for transformerless grid connection systems are presented in [5,6]. Fig.1 shows configurations of MOVS converter with step up and step up/down topologies. These topologies are suitable for renewable energy systems

based on diode-clamped inverter where there is a need for series regulated DC voltage to supply a DC link. However, these configurations may suffer from the number of switches as it leads to increase losses. Also the boost switch ( $S_0$ ) should endure the whole output voltage which can make these configurations inappropriate for high voltage applications.

This paper presents new configurations of MOVS with minimum number of switches for voltage sharing where the output voltages are connected in series. Furthermore, capacitor voltage unbalancing problem can be eliminated as the DC link voltages are generated by the MOVS converters. Two different configurations for a double-output MOVS converter is proposed based on number of switches. Steady state and dynamic analysis of both topologies are discussed as well as control strategies. Simulation results confirm the operation of the configurations.

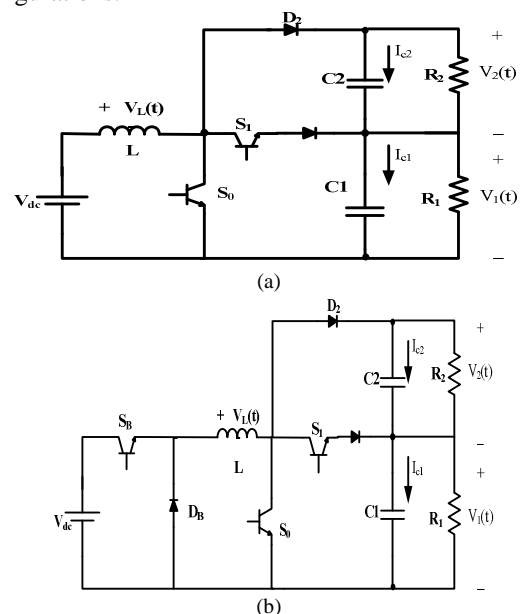

Fig.1. Converter configuration of double-output (a) step-up and (b) step up/down voltage sharing

## 2. Multi-output Voltage Sharing (MOVS) DC-DC Converter

The MOVS is a DC-DC converter with one inductor and series connected capacitors in the output side in order to generate different regulated DC voltage. The series regulated voltage at the DC link voltage of the diode-clamped inverter (Fig.2) can solve the capacitor voltage unbalancing problem and simplify the control of multilevel inverters. Moreover, this configuration is suitable for renewable energy applications such as wind turbine systems where the proposed converter can regulate the variable and low quality output of a high voltage rectifier. Two different configurations for the MOVS converter with different abilities are proposed and analyzed in detail for double-output converters in the following sections.

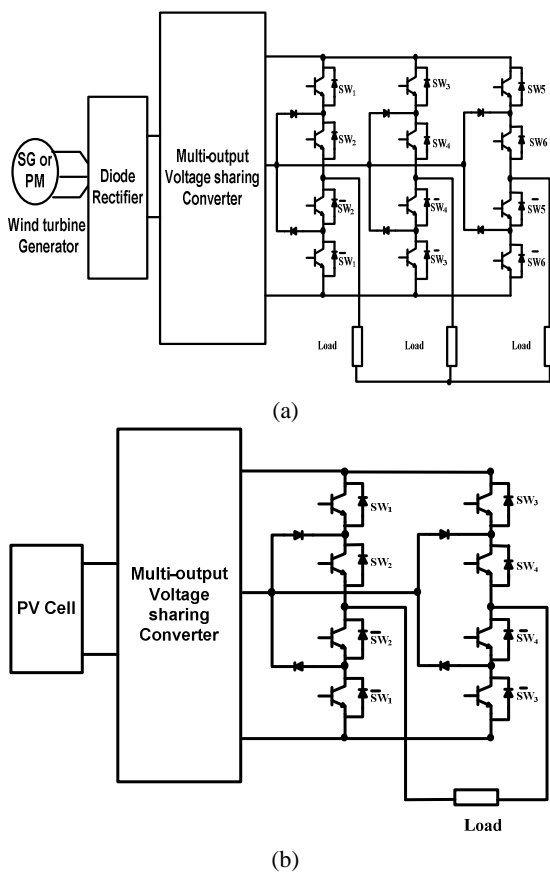

Fig.2. Using MOVS converters in renewable energy systems for (a) three-phase and (b) single phase applications with three-level diode-clamped inverter

### A. Double-output Voltage sharing converter

Fig.3 shows a new double-output voltage sharing converter with one switch. As shown, the power circuit consists of one inductor ( $L$ ); one switch ( $S_1$ ), two diodes ( $D_1, D_2$ ), and two series capacitors ( $C_1$  and  $C_2$ ) at the output. Based on the switching states of  $S_1$  this configuration operates in two different subintervals. Fig.4 illustrates the equivalent power circuit in the two subintervals. As depicted during the first subinterval when  $S_1$  is turned “on”, the diode ( $D_2$ ) obstructs the charging current through  $C_2$  as the voltage across the

diode will be negative. Thus, the switch  $S_1$  conducts and directs the inductor current to  $C_1$ . However, during the second subinterval,  $S_1$  is “off” and the diode ( $D_2$ ) can direct the inductor current to both  $C_1$  and  $C_2$ .

The average amount of inductor voltage ( $V_L$ ) and capacitor current ( $i_C$ ) over one switching cycle are computed as follow:

$$\begin{cases} \langle i_{c1}(t) \rangle = C_1 \frac{d\langle v_{c1}(t) \rangle}{dt} = \\ \langle d_1(t) \rangle \times \langle i(t) \rangle - \frac{\langle v_1(t) \rangle}{R_1} + \langle d_1'(t) \rangle \times \langle i(t) \rangle - \frac{\langle v_1(t) \rangle}{R_1} \end{cases} \quad (1)$$

$$\begin{cases} \langle i_{c2}(t) \rangle = C_2 \frac{d\langle v_{c2}(t) \rangle}{dt} = \\ \langle d_1(t) \rangle \times \langle i(t) \rangle - \frac{\langle v_2(t) \rangle}{R_2} + \langle d_1'(t) \rangle \times \langle i(t) \rangle - \frac{\langle v_2(t) \rangle}{R_2} \end{cases} \quad (2)$$

$$\begin{cases} \langle v_L(t) \rangle = L \frac{d\langle i(t) \rangle}{dt} = \\ \langle d_1(t) \rangle \times \langle v_{dc}(t) \rangle - \langle v_1(t) \rangle + \langle d_1'(t) \rangle \times \langle v_{dc}(t) \rangle - \langle v_1(t) \rangle - \langle v_2(t) \rangle \end{cases} \quad (3)$$

Each variable consists of two parameters, a DC value and a small perturbation signal. The input variables are:

$$\begin{cases} d_B(t) = D_B + \hat{d}_B(t) \\ d_1(t) = D_1 + \hat{d}_1(t) \\ v_{dc}(t) = V_{dc} + \hat{v}_{dc}(t) \end{cases}$$

and the output variables are:

$$\begin{cases} v_1(t) = V_1 + \hat{v}_1(t) \\ v_2(t) = V_2 + \hat{v}_2(t) \\ i(t) = I + \hat{i}(t) \end{cases}$$

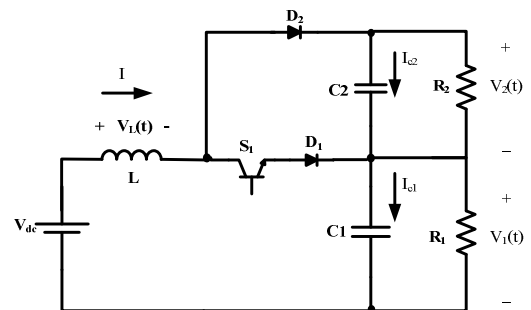

Fig.3. Basic circuit configuration of a double-output voltage sharing

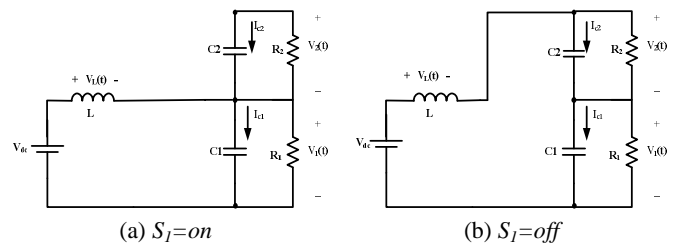

Fig.4. Equivalent circuit of a double-output voltage sharing with one switch in (a) first subinterval (b) second subinterval

In order to study state analysis, capacitors current and inductor voltage are depicted in Fig.5.

In steady state operation, the average capacitor current and inductor voltage over one switching cycle ( $T_s$ ) is equal to zero, thus;

$$\begin{cases} V_{dc} - V_1 - D_1'V_2 = 0 \\ I - \frac{V_1}{R_1} = 0 \\ I - D_1I - \frac{V_2}{R_2} = 0 \end{cases} \quad (4)$$

Also,  $D_1 + D_1' = 1$ . So by solving (4) and (5), the output voltages in steady state can be derived as follow:

$$V_1 = \frac{nV_{dc}}{(n + D_1'^2)} \quad (5)$$

$$V_2 = \frac{D_1'V_{dc}}{(n + D_1'^2)} \quad (6)$$

where  $n = \frac{R_1}{R_2}$ . Inductor current equation is:

$$I = \frac{V_1}{R_1} \quad (7)$$

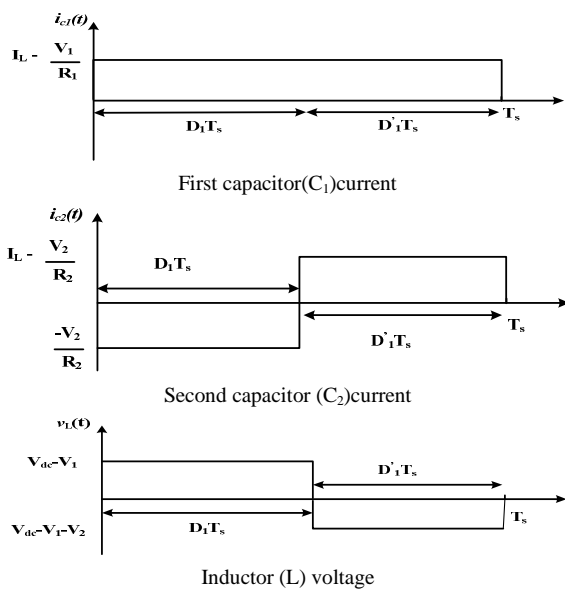

Fig.5. Capacitors current and inductor voltage in two subintervals in double-output voltage sharing converter

By substitution of the small signal part of the variables and linearization of (1) to (3), averaging equations can be rewritten to derive small signal equations:

$$C_1 \frac{d\hat{v}_1(t)}{dt} = \hat{i}(t) - \frac{\hat{v}_1(t)}{R_1} \quad (8)$$

$$C_2 \frac{d\hat{v}_2(t)}{dt} = D_1'\hat{i}(t) - \frac{\hat{v}_2(t)}{R_2} - I\hat{d}_1(t) \quad (9)$$

$$L \frac{d\hat{i}(t)}{dt} = -\hat{v}_1(t) - D_1'\hat{v}_2(t) + \hat{v}_{dc}(t) + V_2\hat{d}_1(t) \quad (10)$$

Rewriting the small signal equations to a state space format, we have:

$$\begin{bmatrix} C_1 & 0 & 0 \\ 0 & C_2 & 0 \\ 0 & 0 & L \end{bmatrix} \begin{bmatrix} \hat{v}_1 \\ \hat{v}_2 \\ \hat{i} \end{bmatrix} = \begin{bmatrix} -\frac{1}{R_1} & 0 & 1 \\ 0 & -\frac{1}{R_2} & D_1' \\ -1 & -D_1' & 0 \end{bmatrix} \begin{bmatrix} \hat{v}_1 \\ \hat{v}_2 \\ \hat{i} \end{bmatrix} + \begin{bmatrix} 0 & 0 \\ 0 & -I \\ 1 & V_2 \end{bmatrix} \begin{bmatrix} \hat{v}_{dc}(t) \\ \hat{d}_1(t) \end{bmatrix} \quad (11)$$

Based on steady state and small signal equations, this converter basically operates as a voltage sharing converter, with different output voltages which can be regulated by adjusting the duty cycle of  $S_1$  in a close loop

control strategy. However, as there is only one control parameter ( $S_1$  duty cycle), one of the output voltages can be controlled for the desired voltage level. This issue will be described in the section with simulation results.

### B. Double-output Step-down Voltage sharing Converter

To be able to control all output capacitors voltages in a voltage sharing converter, a new circuit diagram of the voltage sharing converter with two output-voltages is presented in Fig.6. This circuit includes a buck converter series with a voltage sharing converter.  $S_B$  is the buck converter switch and,  $S_1$  is the double-output voltage sharing converter switch. When  $S_B$  is turned on the inductor can be charged by the current flowing through it and the power circuit can operate in two different subintervals when  $S_1$  is "on" or "off". In the next two subintervals,  $S_B$  remains off and  $S_1$  operates to direct the inductor current either through only  $C_1$  or both  $C_1$  and  $C_2$  when it is on or off respectively. In both switching cases of  $S_B$ , when  $S_1$  is "off", the inductor current can charge both  $C_1$  and  $C_2$  to produce  $v_1$  and  $v_2$ , respectively. On the other hand, when  $S_1$  is "on",  $C_2$  is being discharged through  $R_2$  as reverse current flow is prohibited by the diode, while  $C_1$  is being charged by the inductor current. Consequently, the output voltage level can be controlled by adjusting the duty cycle of each switch (Fig.7).

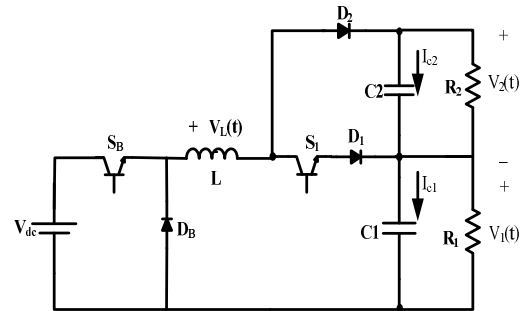

Fig.6. A circuit diagram of a double-output step-down voltage sharing

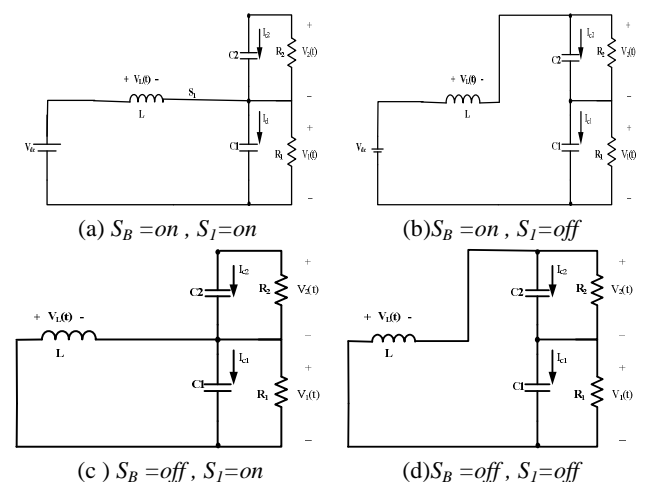

Fig.7. Equivalent circuit of a double-output step-down voltage sharing in (a) first subinterval (b) second subinterval (c) third subinterval (d) fourth subinterval

The average amount of inductor voltage and capacitor current over one switching cycle are considered likewise as Eq.1 to Eq.3. Therefore, capacitors voltage and inductor current are depicted in Fig.8.

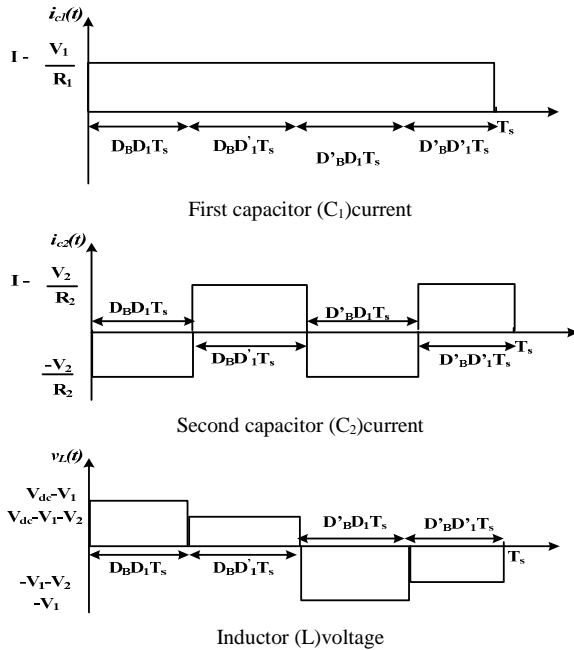

Fig.8. Capacitors current and inductor voltage in four subintervals in the double-output step down voltage sharing converter

Regarding the fact that in the steady state operation, the average capacitor current and inductor voltage over one switching cycle is equal to zero, the average output voltage can be calculated:

$$V_1 = \frac{D_B V_{dc}}{(1 + nD_1^2)} \quad (12)$$

$$V_2 = \frac{nD_B D_1' V_{dc}}{(1 + nD_1'^2)} \quad (13)$$

where  $n = \frac{R_1}{R_2}$ . Also, the average inductor current equation

is same as Eq.7.

By substitution of a small signal part of the variables and linearization of averaging equations similar to (9) to (11), small signal modeling equations for a double-output step-up voltage sharing converter are written as a state space format as below:

$$\begin{bmatrix} C_1 & 0 & 0 \\ 0 & C_2 & 0 \\ 0 & 0 & L \end{bmatrix} \begin{bmatrix} \hat{v}_1 \\ \hat{v}_2 \\ \hat{i} \end{bmatrix} = \begin{bmatrix} -\frac{1}{R_1} & 0 & 1 \\ 0 & -\frac{1}{R_2} & (1-D) \\ -1 & -(1-D) & 0 \end{bmatrix} \begin{bmatrix} \hat{v}_1 \\ \hat{v}_2 \\ \hat{i} \end{bmatrix} + \begin{bmatrix} 0 & 0 & 0 \\ 0 & 0 & -I \\ D_B & V_{dc} & V_2 \end{bmatrix} \begin{bmatrix} \hat{v}_{dc}(t) \\ \hat{d}_B(t) \\ \hat{d}_1(t) \end{bmatrix} \quad (14)$$

### 3. Simulation results

The objective of this section is to verify the proposed topologies by comparing the theoretical results with the simulation results at different operation modes. As presented in the final equations, the output voltages of the proposed configurations can be controlled by the duty cycles of the switches. Therefore, a closed loop control strategy is applied for each converter to control the voltage sharing. Simulations are carried out for the

double-output converters. However, it can be easily implemented for multi-output converters. The power circuit parameters for different configurations are presented in Table. I. The input voltage of each converter is an output voltage of a diode rectifier with high variation. A case study has been conducted when the desired output voltages are controlled to obtain the same value.

Table I. - Power circuit parameters

Inductance value	$L$	1mH
Capacitance value	$C_1=C_2$	100 $\mu$ F
Output voltages for MOVS	$V_{1ref}$	70V
Output voltages for MOVS in step down topology	$V_{1ref}=V_{2ref}$	70V

Voltage control block diagram of the double-output voltage sharing converter demonstrated in Fig.9. In this control method,  $V_1$  is simply being controlled by  $S_1$ . In this case, once the voltage error of first output voltage is above the dead band  $S_1$  is turned off, otherwise it is turned on. Therefore, the duty cycle of  $S_1$  may be adjusted based on the reference voltage of  $V_1$  in the double-output voltage sharing. Although the voltage of the first output is controlled, there is no control on the second output voltage due to limitations of switching states. These limitations were addressed in the steady state analysis and in Fig.10.

A Block diagram of a control strategy for the double-output step down voltage sharing converter is depicted in Fig.11. The voltage control of  $V_1$  is performed same as the double-output voltage sharing control strategy while there are switching states in the double-output step down voltage sharing converter to control both output capacitors voltage. The duty cycle of  $S_B$  is controlled to regulate the entire output voltage. By doing so, both output voltages can be controlled. Simulation results for the double-output step down voltage sharing converter are shown in Fig.12. As it depicted, input voltage is a output voltage of the rectifier with high variation of about 100V. The output voltages are properly controlled to the same value of 70 V and with less than 10 V variations which shows the performance of this proposed circuit to comprehensively share and control the high variation of input voltage into different voltage levels.

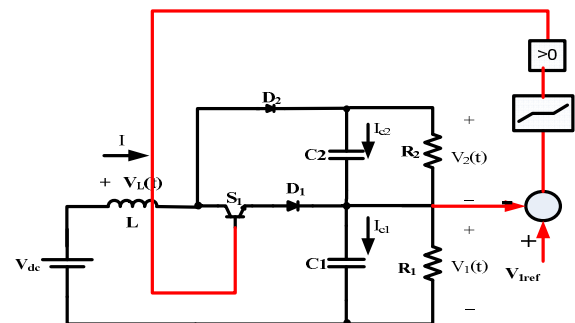

Fig.9: Block diagram of control strategy for double-output voltage sharing converter

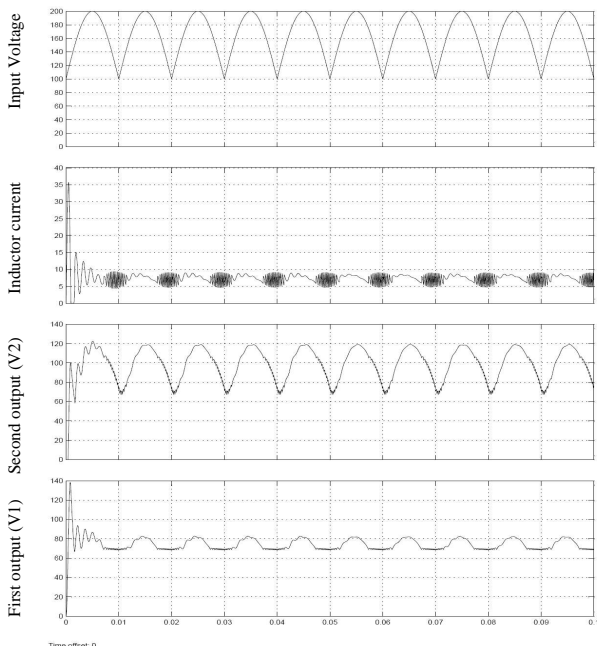

Fig.10: Waveforms for double-output voltage sharing converter. From up to down: rectified input voltage, inductor current ( $i_L$ ), first output voltage ( $V_1$ ), and second output voltage ( $V_2$ )

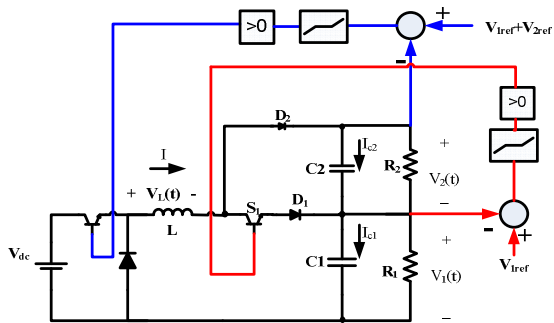

Fig.11: Block diagram of control strategy for double-output step down voltage sharing converter

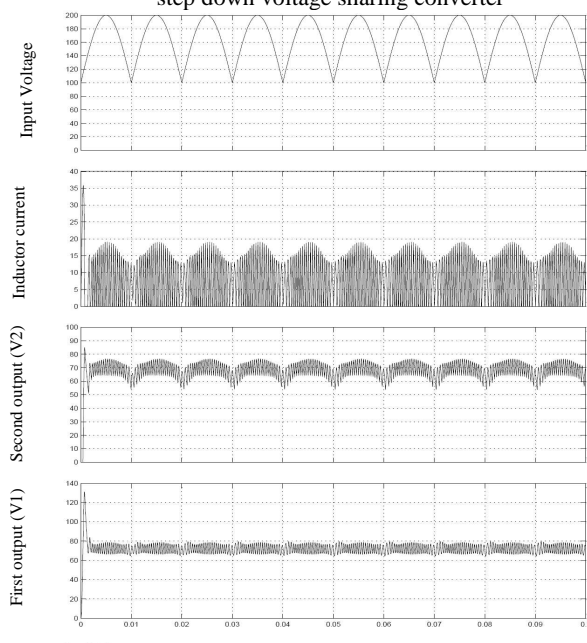

Fig.12: Waveforms for double-output step down voltage sharing converter. From up to down: rectified input voltage, inductor current ( $i_L$ ), first output voltage ( $V_1$ ), and second output voltage ( $V_2$ )

## 4. Discussion

The double-output DC-DC converter with one switch is the simplest configuration of multi-output DC-DC converters which are suitable for transformerless connection system based on diode-clamped topology. Also it would be a suitable configuration for high power application as the boost switch is removed compared with previous configurations. However, there is a limitation to control both output voltages, when input voltage fluctuates. The double-output step down converter is a good solution to solve this limitation as it can remove any fluctuation of input voltage in output voltages. However it has one more switch which impose extra cost and losses in MOVS converter topology. Therefore based on different applications a proper configuration can be chosen.

## 5. Conclusion

In this paper new configurations with controlled output voltages to supply diode-clamped multilevel inverter are proposed and two different power circuits are presented for voltage sharing with different abilities. Regarding steady state analysis and modeling equations, the double-output voltage sharing converter is the simplest configuration with one switch to share the voltage. However, it has a limitation to regulate both output voltages. To solve this limitation double-output configuration with two switches is proposed. The step down voltage sharing converter is a suitable choice for high power application when a high unregulated rectified voltage should be connected to a diode-clamped converter. Above double-output configurations can be easily extended for multi-output converters.

## Acknowledgement

The authors thank the Australian Research Council (ARC) for the financial support for this project through the ARC Discovery Grant DP0774497.

## References

- [1]A. J. Forsyth and S. V. Mollov, "Modelling and control of DC-DC converters," Power Engineering Journal [see also Power Engineer], vol. 12, pp. 229-236, 1998.
- [2]Y. Xie and J. Gan, "Study on the voltage stability of multi-output converters," in Power Electronics and Motion Control Conference, 2004. IPEMC 2004. The 4th International, 2004, pp. 482-486 Vol.2.
- [3]R.Werickson, Fundamentals of Power Electronics. Boston,MA: Kluwer, 1999.
- [4]M. Dongsheng, K. Wing-Hung, T. Chi-Ying, and P. K. T. A. M. P. K. T. Mok, "Single-inductor multiple-output switching converters with time-multiplexing control in discontinuous conduction mode," Solid-State Circuits, IEEE Journal of, vol. 38, pp. 89-100, 2003.
- [5]A. Nami, F. Zare, G. Ledwich, A. Ghosh, and F. Blaabjerg, "A new configuration for multilevel converters with diode clamped topology," in Power Engineering Conference, 2007. IPEC 2007. International, 2007, pp. 661-665.
- [6]A. A. Boora, F. Zare, G. Ledwich, and A. Ghosh, "A New DC-DC converter with multi output: topology and control strategies," Accepted for presentation at EPE-PEMC 2008.