

Improved Structure for Three-Phase Four-Wires Hybrid Active Power Filters

Lucas Frizera Encarnação¹, João Amin Moor Neto², Mauro Sandro dos Reis³ and Mauricio Aredes⁴

¹ Department of Electrical Engineering - University of Espírito Santo, e-mail: lucas@ele.ufes.br

² Department of Electrical Engineering - CEFET/RJ, e-mail: jamoor.neto@gmail.com

^{3/4} Electrical Engineering Program - University of Rio de Janeiro, e-mail: mauro@lemt.ufrj.br, aredes@lemt.ufrj.br

Abstract. This paper presents a novel three-phase four-wire low power rating flexible hybrid active filter with a power factor, harmonic and neutral currents capability for distribution systems. The passive filter is tuned to compensate the two largest harmonics components and the power factor of the load. A selective algorithm is employed in order to enable the active filter to compensate only the desirable harmonic components. Simulation results are presented in order to verify the performance of the proposed hybrid filter.

Key words

Harmonic compensation, Hybrid Active Filters, Power Quality, Reactive Power Compensation, Selective Algorithm.

1. Introduction

Regardless of the economic activities, all costumers depend, on some level, on electrical energy quality and network efficiency. Historically, the costumers were only interested in reduce their energy cost by compensating the reactive energy. However, with the increase of electric-electronics equipments in the distribution systems, nowadays the costumers are interested also in the electrical waveform quality in order to protect and guarantee a proper functioning of these sensitive loads. In fact, the improvement of power factor can release electrical capacity of the distribution system, improve the voltage level, reduce the system losses and optimize electrical energy costs. In this context, shunt capacitors have been installed in specific locations of the distribution feeders in order to compensate the reactive power. However, the widespread use of nonlinear loads can generate current harmonics and/or voltage harmonics that deteriorates the power quality of the distribution feeders and the application of shunt capacitors can lead to serious problems. Traditionally, in order to overcome the harmonic and reactive flow related problems, shunt passive filters have been adopted for a long time, but their practical applications provide limited solution to these power quality problems and have some disadvantages, such as large size equipments, fixed tuning and risk of resonance [1]. The series/parallel resonance may result in over-current/over-voltage and can damage the passive filter. Furthermore, the harmonics currents produced by

neighboring nonlinear loads may flow into the passive filter, resulting in overload situation.

The drawbacks of passive filters have increased the interest on active filtering applications. In this context, different topologies and control strategies of active power filters have been analyzed and discussed in the literature [2]. Due to this great interest in active filtering, some ideas emerged using the traditional passive filters combined with the active filters, resulting in the proposal of different hybrid filter topologies [3-5]. An effective hybrid active filter structure consists of active and passive resonant filter connected in series, which results in a lower required rated voltage source converter. Therefore, due to the low voltage level, the small shunt active filter can be connected in series with the shunt passive filter without using any coupling transformer. This hybrid active filter is characterized by a low dc-link rating with similar filtering performance with active power filters [6-9]. Some hybrid filter topologies coupling the voltage source converter to the distribution feeders through series resonant filters have been presented for three-phase four-wire systems [9-13]. A classical topology based on three-phase three-leg converter with two split capacitors at the DC bus is showed in Figure 1.

Figure 2 shows a similar structure with a single capacitor at the DC bus and in this case the neutral wire is connected to negative point at the converter DC bus [11]. Another quite similar structure based on three-phase three-leg converter that uses a single capacitor at the DC bus is showed in Figure 3, which the negative point is connected to neutral wire by a specific inductor [10].

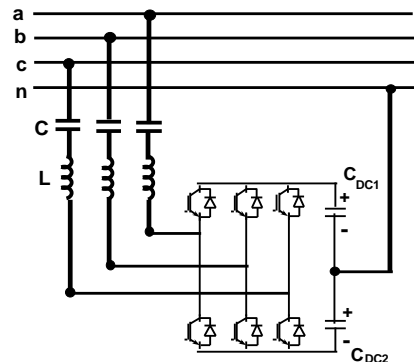

Fig. 1. Three-phase four-wire hybrid filter with split capacitor.

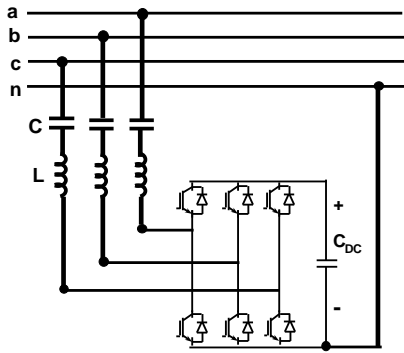

Fig. 2. Three-phase four-wire hybrid filter with asymmetric neutral connection.

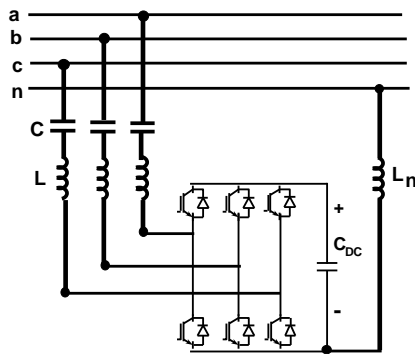

Fig. 3. Three-phase four-wire hybrid filter with neutral inductor.

The neutral wire also can be connected directly in one leg of the converter. In this context, a classical topology based on three-phase four-leg converter is showed in Figure 4.

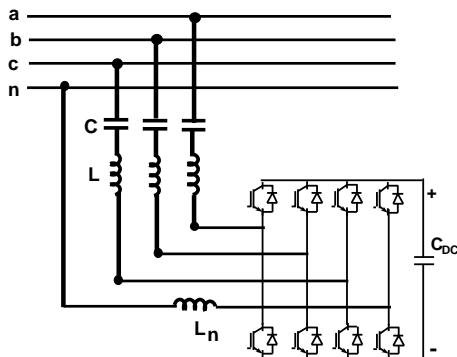

Fig. 4. Three-phase four-wire hybrid filter with four-leg converter.

In this work, the compensation performance of a new hybrid active power filter topology developed for three-phase four-wire distribution system is presented and analyzed. This topology was based on hybrid active power filter topology presented in [12]. In the proposed topology the four-leg converter was inserted between the capacitors and the two inductors groups of the shunt passive filter tuned for the 5th and 3rd harmonic order. This new configuration keeps the harmonic mitigation capability for a lower cost than the similar topology and presents more flexibility when the active filter is disconnected from the system. The paper shows that this proposed structure provides a reduction of inverter power rating by decreasing both its line current and line-to-line voltage. A preliminary analysis of the converter power losses also is discussed in this work.

2. Proposed Hybrid Filter Topology

The proposed three-phase four-wire hybrid active power filter topology is shown in Figure 5, which consists of a series connected two inductors and one capacitor set with a small-rating power converter. The structure of the proposed hybrid filter was based on the combination of the b-shaped one-branch and b-shaped L-type passive filters topologies, shown in Figure 6 [12] and Figure 7 [13-14], respectively.

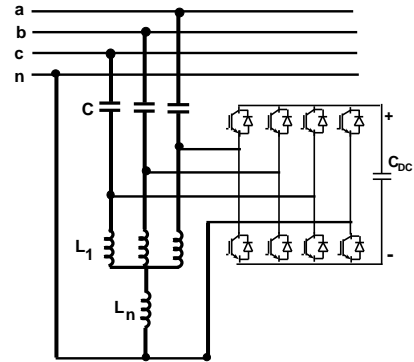

Fig. 5. Three-phase four-wire proposed hybrid filter.

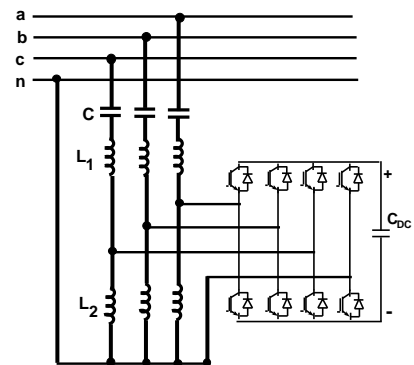

Fig. 6. Three-phase four-wire b-shaped L-Type hybrid filter.

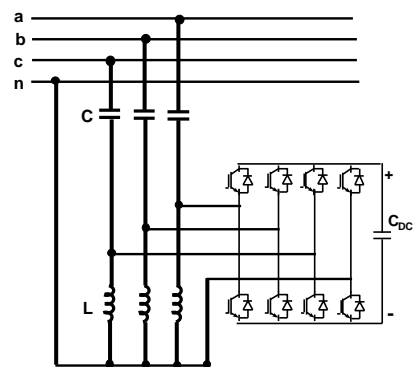

Fig. 7. Three-phase four-wire b-shaped one-branch hybrid filter.

The passive filter structures of the proposed hybrid filter and the b-shaped L-type are similar. Both topologies have two set of inductors, L_1 - L_n and L_1 - L_2 , respectively. However, the proposed topology has a single inductor installed in neutral of the system instead of three inductors in each phase, that present a resonant frequency for the zero sequence components. Meanwhile, the active filter connections of the proposed topology and the b-shaped one-branch are set between the capacitor and the inductor. However, the b-shaped one-branch structure has only one

inductor per phase. In the original power circuit configurations, shown in Figure 6 and Figure 7, the passive filter can be kept the operating even when the active filter is disconnected. This is an important operational aspect for the reliability of distribution systems. However, in both topologies, only one resonance frequency can be obtained, usually the third harmonic.

In the proposed structure, with the active filter disconnected, the proposal topology has advantage in this operational situation because the passive filter can simultaneously drain the third and fifth harmonic components. On the other hand, the passive filter that composes the b-Shaped L-Type Hybrid Active Power Filter can drain only the third harmonic component in the same operational situation. This factor makes the proposal topology interesting by its reliability and greater operational flexibility.

The b-shaped L-type topology presents a lower switching noise injection than the b-shaped one-branch topology due to the series connected inductor L_1 and capacitor C that forms a L_1C filter as shown in Figure 6. However, this topology presents a higher cost and size [12]. The proposal topology presents lower cost and lower size than the b-shaped L-type topology but the switching noise injection is normally higher.

In the hybrid active filter shown in Figure 6, the tuning of the passive filter was defined to eliminate the two most dominant harmonics. The capacitance C and inductance L_1 will be tuned at the second more dominant harmonic order and the set defined by C , L_1 and L_2 will be tuned at the first dominant harmonic order [12]. Thus, the passive filter will act in the two largest harmonics regardless of active filter. This assumption was maintained in the tuning of the proposed topology. However, if the passive filter C and L_1 would be tuned to 7th harmonic frequency, instead of the 5th harmonic order, the passive filter would be less bulky for the same filter capacitor C [16]. The choice to eliminate the 5th harmonic component was due to the fact that the passive filter can be operated itself. Thus, one can ensure the elimination of largest harmonics magnitudes with the active filter turn off.

The passive filter set of the proposed topology was tuning to presents a resonance frequency for positive and negative sequence components and zero sequence components [10].

The capacitor C and the inductor L_1 forms a L_1C passive filter tuned to fifth harmonic component and the resonance frequency are given by (1)

$$f_5 = \frac{1}{2\pi\sqrt{L_1C}} \quad (1)$$

The capacitor C and both inductors L_1 and L_n forms a $L_{12}C$ passive filter tuned to third harmonic component and the resonance frequency is given by (2)

$$f_3 = \frac{1}{2\pi\sqrt{(L_1 + 3L_n)C}} \quad (2)$$

In this proposal topology the passive filter presents an important characteristic to drain both harmonics currents components itself or in a combined operation with the active filter.

3. Control Strategy of the Active Filter

The main purpose of the control strategy of the active filter is to compensate the others harmonics presented in the distribution system not filtered by the passive filter. In distribution systems the larger harmonic components are, generally, 3rd, 5th, 7th, 9th, 11th, 13th, 15th, 17th and 19th. In this case, the proposed passive filter is already set to compensate the 3rd and 5th harmonics components. Therefore, the control strategy of the active filter will be set to compensate the other harmonic components (7th, 9th, 11th, 13th, 15th, 17th and 19th).

Furthermore, the reference currents, calculated through the control algorithm, are indirectly obtained from the system voltages [17]. This strategy guarantees that the proposed hybrid filter can operate independent of the power flow direction, for example, in a loop distribution system. The block diagram of the proposed control strategy for the active filter is presented in Figure 8.

As can be seen in Figure 8, the only input of the control strategy used to determine the reference currents of the active filter are the systems voltages (v_{Sa} , v_{Sb} , v_{Sc}). The dc-link voltage (v_{dc}) and the currents produced by the converter (i_{fa} , i_{fb} , i_{fc}) inputs are used to regulate de dc-link capacitor voltage and current loop control, respectively.

The synchronizing circuit, presented in Fig. 9, is composed by a PLL (Phase Locked Loop) circuit, which is responsible to detect the frequency and phase angle of the fundamental positive sequence of the system voltage (v_{Sa} and v_{Sb}) and generate the harmonic reference signals used in the detection circuit (v_{ha} and v_{hb}).

The detection circuit, responsible to extract the magnitude and phase of each harmonics components from the systems voltages, is presented in Figure 10. The concepts of the control algorithm are derived from the instantaneous power theory (pq-Theory) [18]. The harmonic components presented in the system voltages changes dynamically as the active filter compensates the harmonics component of the system currents.

Thus the power reference control algorithm, illustrated in Figure 11, uses a PI controller to determine dynamically the phase angle and magnitude of each harmonic component of the system voltages. Finally, the reference powers of each harmonic component (p_h^* and q_h^*) are used in the pq-Theory to determine the harmonic currents (i_h^*) that have to be drained by the active filter.

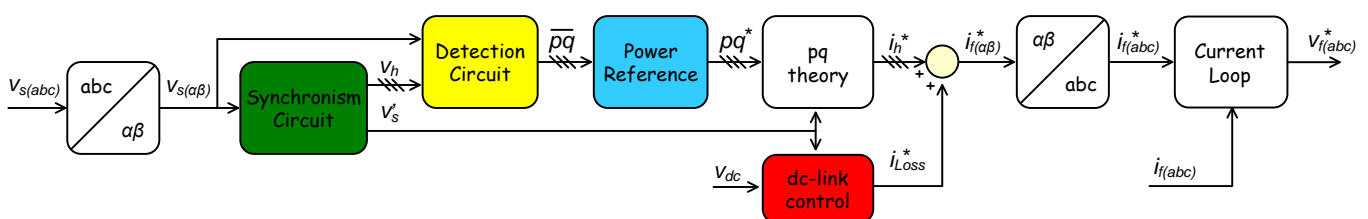

Fig. 8. Block diagrams of the proposed control algorithm

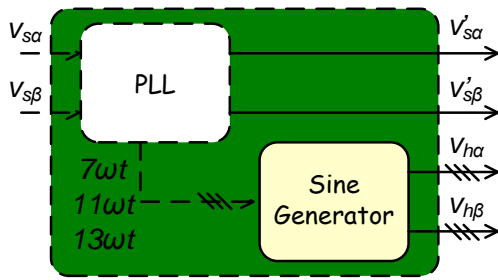

Fig. 9. Synchronizing circuit.

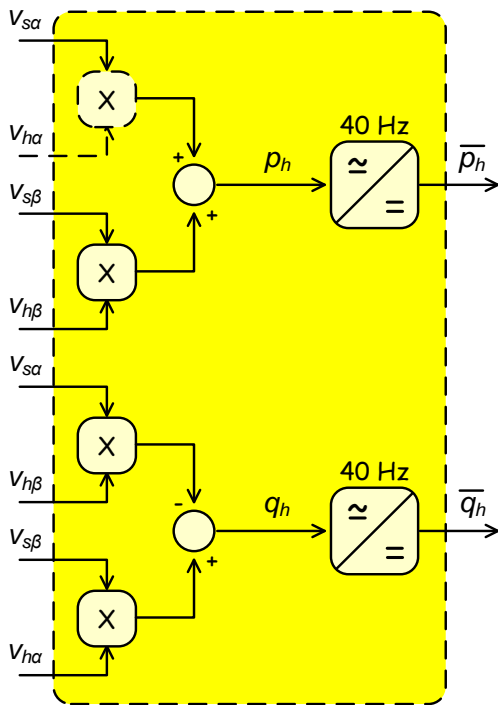

Fig. 10. Detection circuit.

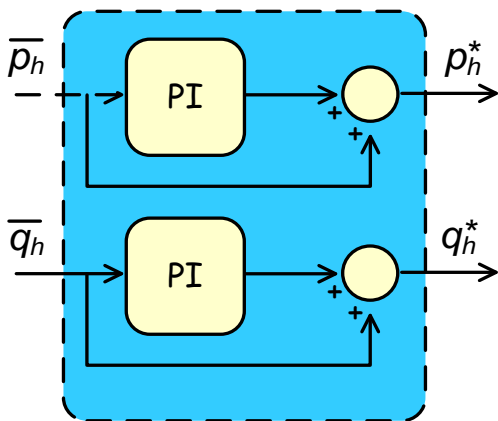

Fig. 11. Power reference circuit.

The dc-link and current loop control circuits present a usual algorithm and, therefore, they will not be presented in this paper.

4. System Modeling and Simulation Results

Figure 12 shows the power circuit of the proposal hybrid active power filter applied to a basic low voltage distribution system. This circuit was modeled, simulated and analyzed by means PSCAD/EMTDC environment.

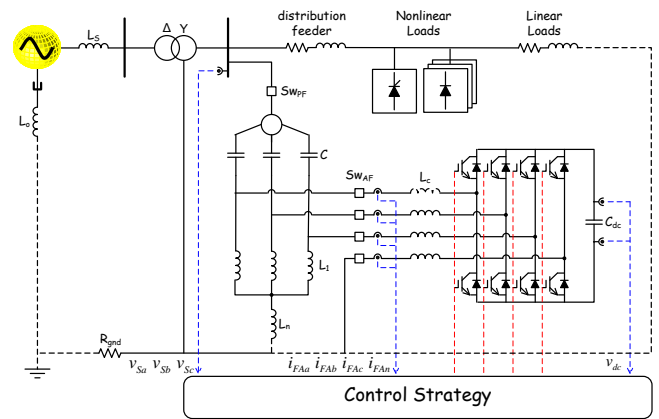

Fig. 12. Power circuit of the distribution system and hybrid filter.

A. Power System Modeling

The medium voltage network was simplified using the sequence impedances representation at PCC. The positive and zero inductive reactance sequences were calculated using the information of the three-phase and single-phase short circuit capacity. The three-phase distribution transformer presents two winding 11.4 kV/220 V with a delta-star point grounded configuration, with a power rating equal to 75 kVA, and short circuit impedance (positive sequence leakage reactance) equal to 3.5 %. The neutral point of the low voltage side of the transformer is grounded by an 80 Ω resistor (R_{gnd}). The low-voltage feeder was modeled by means coupled PI section with positive and zero sequence impedances representing a 53 mm aluminium cable with a distance of 30 meters. The load is composed by a linear load (RL) and nonlinear loads (three-phase and single-phase rectifiers), with an apparent power equal to 35 kVA with an inductive power factor equal to 0.82 and a current total harmonic distortion (*THDi*) of 14.8%.

B. Passive Filter Design

The filtering capacitance C was calculate for compensate the power factor of the load to, at least to 0.94 inductive. In this context, for this load scenario, it is necessary a 9.82 kVar capacitor bank. Therefore, a commercial capacitor bank of 10 kVar / 220 V (capacitance value equal to 684.8μF/per phase) was chosen for the power factor correction. Now, with the filtering capacitance defined, (1) and (2) can be used in order to calculate de phase and the neutral inductors (L_1 and L_n) to set the resonance frequencies of the passive filter to the 3rd and 5th harmonic. Table I summarize the system parameters for simulation.

C. Simulation Results

The power circuit was simulated with three different stages. The first one, the passive and the active filters were turned off (SW_{PF} and SW_{AF} open). At the second stage, only the passive filter is turned on (SW_{PF} closed and SW_{AF} open). At last, in the final stage, the active filter enters combined with the passive filter (SW_{PF} and SW_{AF} closed).

Table I. - Systems Parameters Simulation Summary

Parameters	Symbol	Value
Medium / Low voltages	v_s	11.4 /0.22 kV
Three-phase short circuit capacity	L_s	55 MVA
Single-phase short circuit capacity	L_o	18 MVA
Positive seq. leakage reactance	x_s	0.035 pu
Transformer no load losses	$P_{no-load}$	0.0044 pu
Transformer copper losses	P_{copper}	0.0153 pu
Positive sequence resistance 53mm AL	r_+	0.6641 Ω /km
Zero seq.resistance 53mm AL	r_o	1.7012 Ω /km
Positive seq inductive reactance 53mm AL	x_+	0.1311 Ω /km
Zero seq.inductive reactance 53mm AL	x_o	1.0492 Ω /km
Filtering capacitance	C	684.8 μ F
Filtering inductance	L_l	411 μ H
Neutral filtering inductance	L_n	244 μ H
Inverter inductance	L_c	250 μ H
dc-link storage capacitance	C_{dc}	2500 μ F
Switching frequency	f_s	10 kHz

The instantaneous three-phase and neutral load currents before compensation are presented in Figure 13(a). In this case, with no compensation, the source current at the low voltage side of the transformer is the same of the load current. Figure 13(b) and (c) presents the source current at the low voltage side of the transformer with only the passive filter and with the hybrid active filter compensation, respectively. The improvement of the current total harmonic distortion ($THDi$), observed in Figure 13(b), is possible only because the passive filter topology compensate, at the same time, the 3rd and 5th harmonics even without the active filter connected in to system. Furthermore, when the active filter is turned on, another improvement on the $THDi$ was achieved. In this case, the active filter selective control algorithm compensates only the 7th, 11th, 13th, 15th, 17th and 19th harmonic components, optimizing the $THDi$.

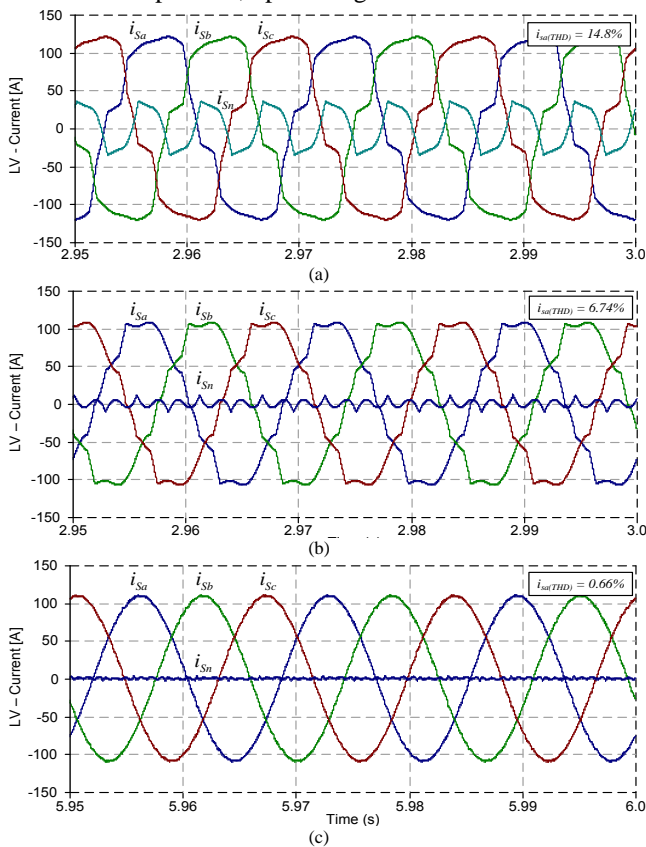

Fig. 13. Source current (LV) without compensation (a), passive filter (b) and hybrid filter compensation (c).

The instantaneous phase voltage (v_{sa}) and current (i_{sa}) of the transformer low voltage side, without compensation and with the passive filter and hybrid active filter compensation, are presented in Figure 14(a), (b) and (c), respectively.

From Figure 14(b), the proposed passive filter can compensate the power factor of the distribution system and compensate the 3rd and 5th harmonics. Furthermore, it can be observed in Figure 14(c) that the active filter do not change the power factor of the distribution system. This is an important advantaged, because requires less current from the active filter, decreasing more the nominal power of the converter. However, if a power factor control circuit is needed, for example in a distribution system with a significant variation of the reactive power, the active filter can improve dynamically a percentage of the power factor. However, in this case, a current measurement will be necessary in order to calculate the power factor and more nominal power of the active filter will be needed. Since the purpose of this work is to reduce the rated power of the active filter, the reactive power control loop will be discarded.

Figure 15 presents the regulated dc-link capacitor voltage (v_{dc}) and the rms current of the active filter for phase a (i_{Afa}). The dc capacitor was pre-charged to 65 V_{dc} and at 3.3 seconds of simulation the active filter is connected into the system and the dc-link control algorithm is turned on.

The total rms current, for one phase of the converter, is 4.4 Arms. The rated power of the active filter was calculated through the output AC voltages and currents of the equipment. Therefore, the calculated rated power of the active filter was 300 W, proving the low rated power of the equipment.

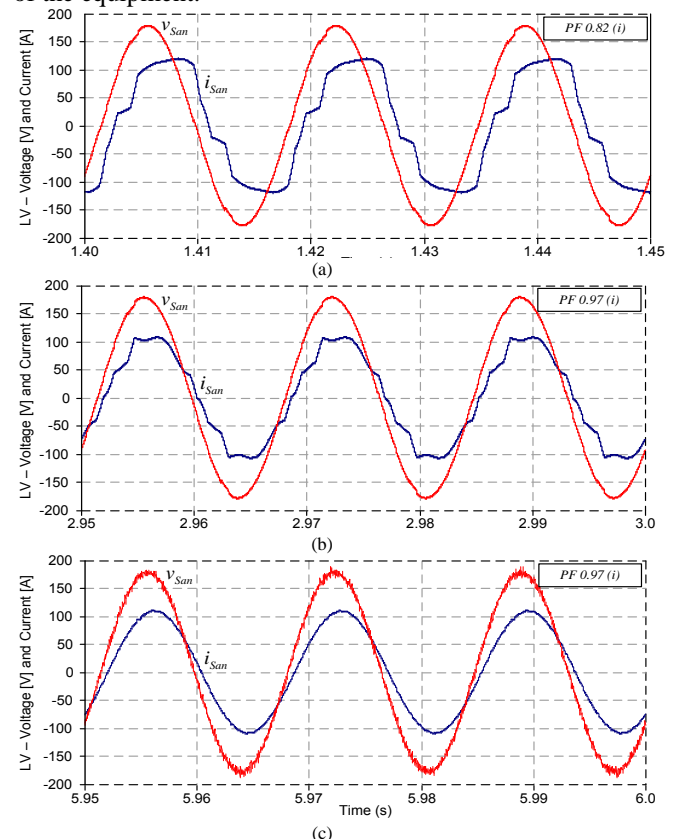

Fig. 14 Source PF without (a) and with the passive filter (b).

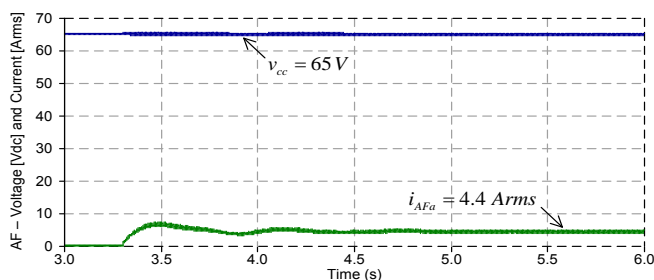

Fig. 15 dc-link capacitor voltage and rms current of the active filter.

5. Conclusions and Future Works

In this paper was presented a new three-phase for-wire hybrid active filter structure enable to compensate reactive power, harmonics and neutral current. This hybrid active filter is characterized by operational flexibility and allows the simultaneous compensation of 3rd and 5th harmonics even without the connection of active filter. This factor makes the proposal topology interesting by its reliability and greater operational flexibility. Furthermore, the proposed active filter topology can reduce the nominal power rating of the active filter, without compromise the operational performance of the hybrid filter.

The simulations results prove the flexibility and viability of the proposed hybrid filter. The control algorithm of the hybrid active filter can extract the phase angle and magnitude of the selected harmonics by only monitoring the system voltages. This is an important advantage because guarantees that the proposed hybrid filter can operates independent of the power flow direction, for example, in a loop topology or in a radial topology with possibility of reconfiguration distribution systems.

References

- [1] J. C. Das, "Passive Filters, Potentialities and Limitations", IEEE Trans. on Industry Applications, vol. 40, no.1, pp. 232-241, Jan./Feb. 2004.
- [2] M. El-Habrouk, M. K. Darwish, P. Mehta, "Active Power Filters: A Review", IEE Proc.-Electr. Power Appl., vol. 147, no. 5, pp. 403-413, September, 2000
- [3] L.Chen, A. V. Jouanne, "A Comparison and Assessment of Hybrid Filter Topologies and Control Algorithms", IEEE Power Electronics Specialists Conference -PESC, vol. 2, pp. 565-570, 2001.
- [4] S. T. Senini, P. J. Wolfs, "Systematic Identification and Review of Hybrid Active Filter Topologies", IEEE Power Electronics Specialists Conference -PESC, vol. 1, pp. 394-399, 2002.
- [5] T. Jain, S. Jain, G. Agnihotri, "Comparison of Topologies of Hybrid Active Power Filter", IET- UK International Conference on Information and Communication Technology in Electrical Sciences – ICTES, pp. 503-509, 2007.
- [6] H. Hakagi, "A Medium Voltage Transformerless AC/DC Power Conversion System Consisting of a Diode Rectifier and a Shunt Hybrid Filter", IEEE Industry Application Society - IAS Annual Meeting, vol.1, pp.78-85, October 2002.
- [7] H. Akagi, "Modern Active Filters and Traditional Passive Filters", Bulletin of the Polish Academy of Sciences – Technical Sciences, Vol. 54, No. 3, pp. 255-269, 2006.
- [8] Z. Chang-zheng, C. Qiao-fu, Z. You-bin, C. Yu-da, X. Bing-ruo "Research on a Novel Shunt Hybrid Active Power Filter", Proceedings of the CSEE – Chinese Society For Electrical Engineering, vol. 27, no. 19, pp. 110-114, October 2007.
- [9] B. Singh, V. Verma, A. Chandra, K. Al-Haddad "Hybrid filters for power quality improvement", IEE Proc. on Gener. Transm. Distrib., pp. 365-378, Vol. 152, May 2005.
- [10] J. I. Candela, P. Rodriguez, A. Luna, R. Teodorescu, F. Blaabjerg, "Proposal of a Resonant Controller for a Three Phase Four Wire Grid- Connected Shunt Hybrid Filter", IEEE Energy Conversion Congress and Exposition - ECCE, pp. 573 – 577, September 2009.
- [11] M. Lamich, J. Balcells, J. Garcia, D. Gonzalez, J. Gago, "New Structure for Three-Phase Four Wires Hybrid Active Filters", IEEE Industrial Electronics – IECON Annual Conference, pp. 1603 – 1608, November 2006.ong, T. Tmai, "Comparisons
- [12] C.S. Lam, M.C. Wong, "A Novel b-shaped L-type Transformerless Hybrid Active Power Filter in Three-Phase Four-Wire Systems", 38th North American Power Symposium (NAPS), pp. 235-241, 2006.
- [13] C.S. Lam, M.C. Wong, "System and control design of a hybrid active power filter in three-phase four-wire system", 3rd International Conference on Power Electronics Systems and Applications – PESA, pp. 1-5, 2009.
- [14] S. Park, J.-H. Sung, and K. Nam, "A new parallel hybrid filter configuration minimizing active filter size," in Proc. IEEE 30th Annual Power Electronics Specialists Conf., PESC. 99, vol: 1, 1999, pp. 400– 405.
- [15] J. H. Sung, S. Park and K. Nam, "New Hybrid Parallel Active Filter Configuration Minimizing Active Filter Size", IEE Proc.-Electrical Power Application, Vol.147, No.2 March, 2000
- [16] H. Akagi, S. Srianthumrong, Y. Tamai, "Comparisons in Circuit Configuration and Filtering Performance Between Hybrid and Pure Shunt Active Filters", IEEE Industry Application Society - IAS Annual Meeting, vol.2, pp.1195-1202, October 2003
- [17] Monteiro, L.F.C., Encarnação, L.F., Aredes, M., "A Novel Selective Control Algorithm for the Shunt Active Filter", in Proc. International Power Electronic Conference, IPEC. 2010, Sapporo, pp. 2288 - 2293.
- [18] Akagi, H., Watanabe, E. H., Aredes, M., Instantaneous Power Theory and Applications to Power Conditioning, Wiley Inter-Science A John Wiley & Sons Inc., IEEE Press Series on Power Engineering, New Jersey, 2007.