



Evaluation of Maximum Power Point Tracking Algorithms for Photovoltaic Electricity Generation in Kuwait

Mohamed A. El-Sayed¹ and Steven Leeb²

¹ Department of Electrical Engineering
College of Engineering and Petroleum, Kuwait University (Kuwait)
Phone: +965 249-83347, e-mail: elsmah@hotmail.com

² Department of Electrical and Computer Engineering
MIT, Cambridge, MA 02139-4307(USA)
Phone: +1 617-253-9360, email: sbleeb@mit.edu

Abstract. Consumption of electrical energy in Kuwait is rapidly increasing. The production of this energy currently depends mainly on oil and its derivatives to drive the different power plants in the country. The combustion of such fossil fuel comes with a well-known environmental pollution. Local oil production represents a key income for Kuwait and intelligent consumption of oil is therefore an essential concern to the Kuwait economy. The power system and economy of Kuwait may benefit from utilizing clean and renewable energy resources such as solar energy.

This paper considers the modelling and control of PV system using in market available modules as an example, and factoring in geographical conditions relevant to Kuwait. As the generated power from PV panel depends on solar irradiation and temperature, the hourly values of these meteorological factors are collected and analysed for a time horizon of 6 years. Based on the system model three widely-adopted MPPT algorithms are compared and their performances are evaluated. Validation of each algorithm model is carried out using MATLAB/Simulink simulations.

Key words: MPPT , DC - DC boost converters, PV arrays, PWM.

1. Introduction

The Ministry of electricity and water in Kuwait (MEW) has estimated that, with the peak load increasing by 6-8% per year, an additional 10,000 MW of installed electrical generating capacity will be necessary by year 2020 [1]. The primary energy source for the existing thermal power stations of Kuwait depends mainly on natural gas and liquid oil products. These power plants are main source of harmful gas emission. Therefore, the country plans to generate 10% of its electricity from renewable energy resources by 2020. In this respect, MEW has taken more direct actions to install PV panels to supply electricity to the building of its headquarters. This generated energy will be used to power light and static loads. As one half of generated energy in Kuwait is consumed for domestic purposes due to air conditioning systems, similar panel would be installed on the roofs of the buildings [1, 2].

According to recent studies [2], the average Kuwaiti house roof dimension is approximately 19mx16m i.e. 304 m². When PV panels cover the roof of this average residential house, they will produce an annual electricity of 65,890 kWh per year [2].

The knowledge of the solar radiation and temperature data is essential for design and sizing of the PV system [3,4]. The temperature variations in Kuwait averaged for each day over 6 years of recorded data are shown in Fig (1). Similarly, Fig (2) displays the average daily solar radiation (SR) on a horizontal surface in Kuwait recorded for the same period. Fig (2) proves that Kuwait has an abundance of solar energy capability. Thereby, the monthly averaged solar intensity on horizontal surface area is 3.26 kWh/m² in December and 8.16 kWh/m² in June. The annual average value of solar radiation reaches 5.9 kWh/m². On the other side the electrical load in Kuwait is characterized by high load in summer and low load in winter depending on the increase and decrease in the values of temperatures and relative humidity. This shows that the peak load matches the maximum incident solar radiation and then its electricity generation, which results in very promising capability for utilizing solar energy in Kuwait to cover electrical demand.

Manufacturers always provide performance data of the PV panels under specific operating conditions. There are many types of such panels in the international market; the most famous of which is the silicon mono semi-crystalline PV type, which has been chosen for further studies in this paper. According to SR in Kuwait the maximum power and maximum efficiency of panel modules is 300 W and 18%, respectively. The module maximum power voltage and current are 53.6 V and 5.6 A, respectively [5].

The PV systems are principally classified according to their mode of operation as stand-alone or grid connected systems. The operation of the stand-alone PV systems is independent on the grid. Recently, there is an increasing interest in installing grid-connected PV systems to form distributed generation. This trend is attributed to economic

and technical benefits of distributed generation in micro-grids. On the other hand, the dispersed grid-connected PV systems require efficient power conditioning converters. The power conditioning devices include DC/DC boost converter and voltage source inverter. Many controlling strategies have been developed [6-8] to control the power conditioning converters. In most PV systems, MPPT algorithms are utilized for full extraction of the available solar energy. The controller adopts the pulse width modulation (PWM) technique to change the converter duty cycles to obtain stable output power close to MPP of the PV array. To select the effective MPPT under the environmental condition in Kuwait, three most popular MPPT techniques are simulated and compared in the paper.

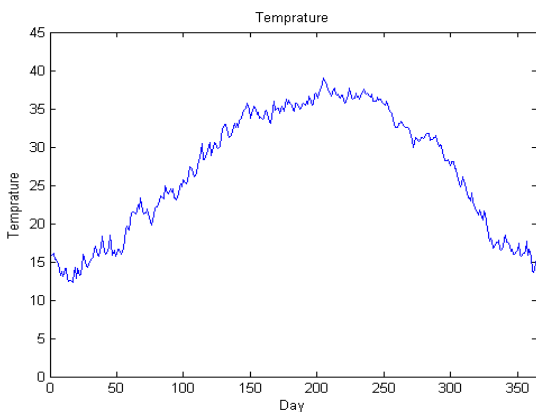

Fig. 1: Average daily temperature ($^{\circ}\text{C}$) in Kuwait, each day averaged over 6 years.

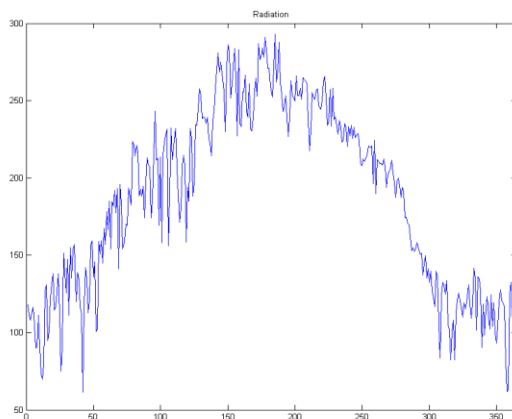

Fig. 2. Average daily solar radiation (W/m^2) in Kuwait, each day averaged over 6 years.

2. Grid connected PV systems

The studied grid-connected PV array has 100 kW capacity corresponding to 300 m^2 roof area of the average house in Kuwait. The array is connected to the grid by means of 250 V/ 11 kV coupling transformer according to the technical standard of the distribution network in Kuwait. Fig. (3) shows the main components of the PV system, which consists of the solar array, DC/DC boost converter, DC link. The main function of DC/DC boost converter is to adapt the generated voltage of the PV panel to a suitable level corresponding to the maximum solar power.

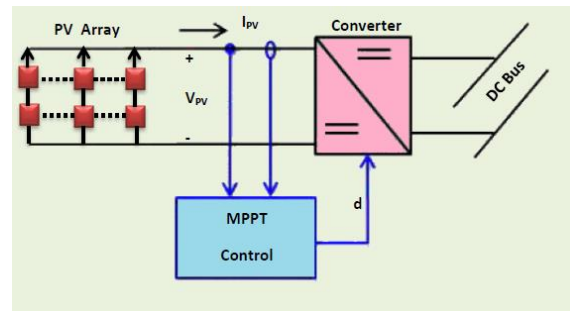

Fig. 3 Components of PV array with maximum power point tracking.

A. Photo-Voltaic Solar Array:

Generally, PV cells are grouped together in similar modules which are interconnected either in series or parallel to form the final PV array. The current-voltage relation of PV array can be mathematically given by [3,4]:

$$I = N_p I_{ph} - N_p I_o \left[\exp \frac{qV}{A K T N_s} - 1 \right] \quad (1)$$

Where,

q: electron charge.

A: P-N junction ideality factor

K: Boltzmann constant.

I: Array output current.

I_{ph} : photocurrent as function of irradiation level and junction temperature

I_o : reverse saturation current of diode.

T: reference cell operating temperature.

V: Array output voltage.

The array output power is determined through multiplying equation (1) by array voltage and efficiency η . Equation (1) indicated that PV array exhibits a non-linear relation of the I-V and P-V characteristics. From P-V curve, there is a specific point at which the generated power is maximum. Therefore, a continuous adjustment of the array terminal voltage is required to extract maximum power (MPP) from the solar array.

B. Boost Converter

A boost converter is a power device with an output DC voltage greater than its input DC voltage. By implementing the PWM technique on boost converter, a stable output voltage can be obtained by changing the duty cycle (d) of the switching device Q to achieve MPP. The boost converter is given in Fig. 4 with a switching period of T and a duty cycle of d. For the conduction mode of operation, the state space equations when the main switch is ON are shown by, [9-10].

$$\begin{cases} \frac{di_L}{dt} = \frac{1}{L} (V_{in}) \\ \frac{dv_o}{dt} = \frac{1}{C} \left(-\frac{v_o}{R} \right) \end{cases}, \quad 0 < t < dT, \quad Q: ON \quad (2)$$

and when the switch is OFF

$$\begin{cases} \frac{di_L}{dt} = \frac{1}{L}(V_{in} - v_o) \\ \frac{dv_o}{dt} = \frac{1}{C}(i_L - \frac{v_o}{R}) \end{cases}, \quad dT < t < T, \quad Q: OFF \quad (3)$$

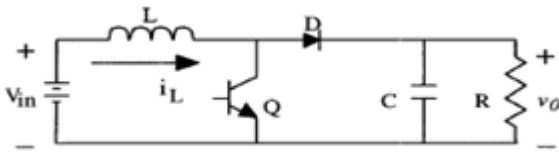

Fig. 4. DC-DC Boost Converter

3. Maximum Power Point Tracking Algorithms

The most widely MPPT techniques available in the literature [11,12] can be summarized as:

A. Constant Voltage Method

The Constant Voltage algorithm is the simplest MPPT control method [7-9]. The operating point of the PV array is regulated near a fixed reference voltage. This method is recommended when the solar insolation and temperature variations are insignificant, so that the MPP voltage at different irradiance is assumed approximately constant. This method does not require any additional input data measurements. However, the array O.C. voltage (V_{oc}) is necessary in order to set up the duty-cycle of the DC/DC converter by its PI controller.

The near linear relationship in the second zone of the I-V curve of PV array between V_{mpp} and V_{oc} , under varying irradiance and temperature levels, has suggested the possibility to substitute V_{mpp} as constant fractional of V_{oc} of the array as follows:

$$V_{mpp} = K_1 * V_{oc} \quad (3)$$

Where k_1 is proportionality constant dependent on the characteristics of the PV array being used. The factor k_1 has been reported to be between 0.71 and 0.78 [9, 10].

B. Perturb and Observe (P&O) Method

In this method the operating voltage of the PV array is perturbed by a small increment, and the resulting change of power, ΔP , is observed [11]. If the ΔP is positive, then the voltage perturbation is moving toward the MPP. This means that further perturbations in the same direction of voltage change will direct the operating point toward the MPP. If the ΔP is negative, the operating point has moved away from the MPP, and the direction of perturbation should be reversed to return back toward the MPP. The basic concept of the P&O algorithm is described in Fig (5) at constant SR and temperature [10,11]. The mathematical formulation of algorithm has 4 cases as follows,

- When $\Delta P < 0$ & $V(j) > V(j-1)$, then $V_{ref} = V(j+1) = V(j) - \Delta V$
- When $\Delta P < 0$ & $V(j) < V(j-1)$, then $V_{ref} = V(j+1) = V(j) + \Delta V$
- When $\Delta P > 0$ & $V(j) < V(j-1)$, then $V_{ref} = V(j+1) = V(j) - \Delta V$

- When $\Delta P > 0$ & $V(j) > V(j-1)$, then $V_{ref} = V(j+1) = V(j) + \Delta V$

The error signal driving the PI controller is equal to the differences between the above adjusted reference terminal voltage, V_{ref} and the actual array voltage.

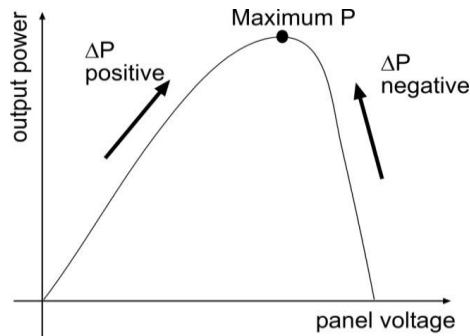

Fig. 5. Power vs. voltage for PV array

When the MPP is approached, V_{pv} may oscillate around the optimal value V_{mpp} depending on the magnitude of the step size. In this respect it should be noted, if this step size is large, the MPPT algorithm responds quickly to sudden changes in environmental conditions. On the other side, if the step size is small the algorithm becomes relatively slow and not be able to respond quickly to rapid changes in temperature or irradiance [13].

C. Incremental Conductance Methods

The incremental conductance [8] method (IC) is based on the fact that the derivative of the output power P_{pv} with respect to the array voltage V_{pv} is equal to zero at MPP [12-14]. The PV array characteristic shows that this derivative is positive to the left of the maximum power point and negative to the right of maximum power point. This leads to the following set of equations:

$$\frac{dI_{pv}}{dV_{pv}} = -\frac{I_{pv}}{V_{pv}} \quad \text{at MPP} \quad (4)$$

$$\frac{dI_{pv}}{dV_{pv}} > -\frac{I_{pv}}{V_{pv}} \quad \text{to the left of MPP} \quad (5)$$

$$\frac{dI_{pv}}{dV_{pv}} < -\frac{I_{pv}}{V_{pv}} \quad \text{to the right of MPP} \quad (6)$$

This means that the MPP can be tracked by comparing the instantaneous conductance I_{pv}/V_{pv} to the incremental conductance dI_{pv}/dV_{pv} . Once MPP has been reached, the operation of PV array is maintained at this point and the perturbation stopped unless a change in dV_{pv} is noted. The IC method offers good performance under rapidly changing atmospheric conditions. The algorithm requires the same measurements of the voltage V_{pv} and the current I_{pv} . To regulate the DC bus voltage, a PI controller is used to control the duty ratio of the converter. The controller gains are determined to correct the error (e) given by equation (7). The initial operating point is set to match a load resistance proportional to the ratio of the open-circuit voltage (V_{oc}) to the short-circuit current (I_{sc}) of the PV array.

$$e = \frac{I}{V} + \frac{dI}{dV} \quad (7)$$

4. Comparison of MPPT Algorithms

Simulink software is used to model the studied grid-connected PV array with a MPPT boost converter as shown in Fig (3). The PV block simulates the nonlinear V-I characteristics of the array at different solar radiations and temperatures. The specifications of studied solar panel are given in Table I.

Table I. - PV Panel Specifications

| Description | Symbol | Value | Unit |
|----------------------------|----------|----------------------|---------------|
| O. C. Voltage | V_{OC} | 20.8 | V |
| S. C. Current | I_{SC} | 3.6 | A |
| O.C.Volt/Temp. Coefficient | K_V | -75×10^{-3} | $V/^{\circ}C$ |
| No. of Series cell/module | N_S | 36 | |
| No. of series module | N_{SS} | 33 | |
| No. parallel module | N_P | 60 | |
| Array power rating at NOTC | P_A | 100 | kW |

In order to verify the MPP trackers for PV system, the described MPPT techniques are compared under different weather conditions in Kuwait to show how they can effectively and accurately tracks the MPP. The simulation is carried using MATLAB/SIMULINK. The output of the MPPT control block is the gating signal which is used to drive the IGBT switching devices of DC/DC converter.

Table II shows the parameters of the DC-DC boost converter. The test data consist of hourly SR and temperature for time horizon of 6 years in Kuwait. This data are applied to check the effectiveness of the described MPPT techniques in producing the maximum annual energy of the photovoltaic systems.

Table II. - Buck-Boost Converter Parameters

| | |
|----------------|--------------|
| Inductance L | 5 mH |
| Capacitance C1 | 100 μ F |
| Capacitance C2 | 6000 μ F |
| Frequency | 5 KHz |

5. Simulation and Numerical Results

For each MPPT technique and for hourly input data, the energy supplied by the PV system was calculated for each month averaged over the studied period of 6 years. The implemented controller for the three MPPT algorithms is PI type with $K_p=2$ and $K_i=0.05$. The same Boost converters with its maximum MPP controller are used for fair comparison. The results are summarized in Table III.

The simulation results indicated that the generation using P&O MPPT is maximum with annual energy of 166233.548 kWh. The P&O and IC algorithms over the year are superior to the CV algorithm. The produced energy using CV technique is the lowest of the three studied MPPT methods with annual value of 165012.804 kWh. This is attributed to the fact, that CV technique does not follow the MPP by holding V_{ref} as constant fraction of V_{oc} under different operating condition.

However, in December and January the generated energy using the CV technique is slightly greater than both IC and P&O techniques. On the other hand, IC has slightly smaller energy production compared to P&O techniques in February, March, April, May August, September, October and November. In addition, the generated energy in June and July using IC MPP technique is maximum compared to that of CV and P&O techniques.

The purposes of the next tests are to investigate the dynamic behaviour of a PV system and to calculate the amount of power, voltage and current using the MPPT PI-controller. It should be noted that the generated power has the same shape as the solar insulation curve, the only difference is a small transient from the rapid insulation variation by using P&O and IC techniques. Comparing the output array voltage, it can be observed that the CV method is more stable with solar insulation variation.

In particular due to lack of space, Fig (6) shows sample of the PV array response using the IC, P&O and CV algorithms. The dynamic response of the PV array indicated that the CV technique delivers the more stable voltage, current and power waveforms with negligible oscillation amplitudes. Table IV indicates some oscillations in voltage, current and power using IC and P&O techniques. This is attributed to the IGBTs switching effect to change the array voltage to track the MPPT.

Table III. - Energy Generated Using MPP Techniques in kWh

| Month | CV | P&O | IC |
|-------|------------|------------|------------|
| Jan | 6402.368 | 6397.408 | 6395.114 |
| Feb | 7492.296 | 7521.864 | 7440.720 |
| Mar | 13050.194 | 13031.284 | 13019.318 |
| Apr | 14500.200 | 14522.400 | 14477.880 |
| May | 19403.458 | 19533.100 | 19489.328 |
| Jun | 20588.460 | 20765.760 | 20779.740 |
| Jul | 21131.274 | 21385.784 | 21399.920 |
| Aug | 19901.690 | 20234.444 | 20183.914 |
| Sep | 16430.160 | 16626.240 | 16577.160 |
| Oct | 12045.360 | 12153.302 | 12120.256 |
| Nov | 7418.340 | 7432.860 | 7430.340 |
| Dec | 6649.004 | 6629.102 | 6618.562 |
| Total | 165012.804 | 166233.548 | 165932.252 |

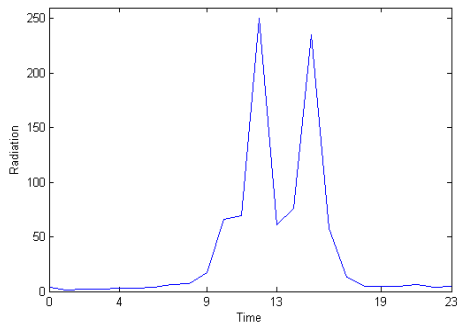

(a) Radiation (kw/m²)

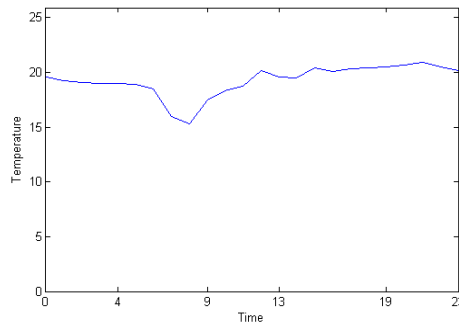

(b) Temperature (°C)

Sample of daily Radiation & Temperature of cloudy day

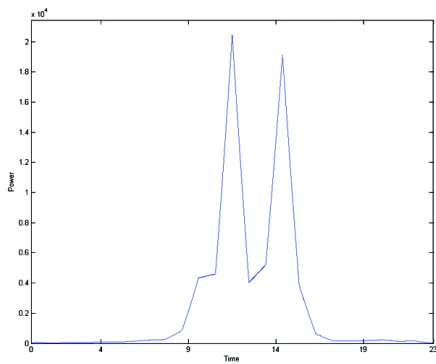

(a) Power (w)

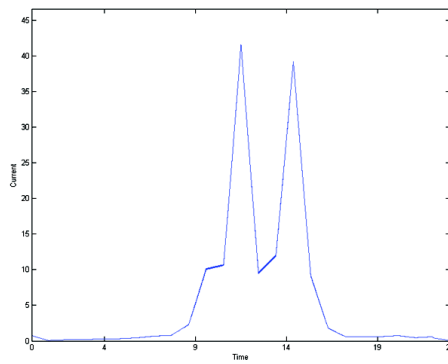

(b) Current (A)

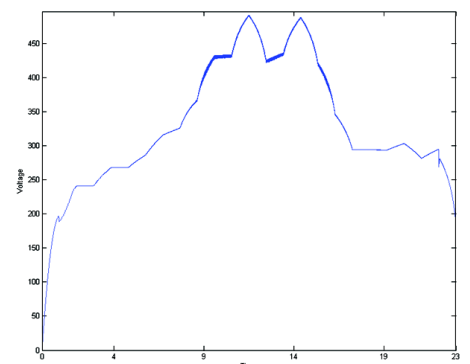

(c) Volt (V)

Using CV algorithm

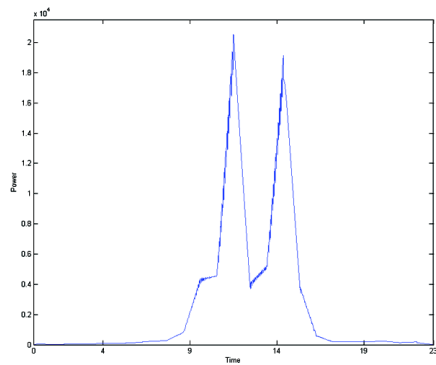

(a) Power (w)

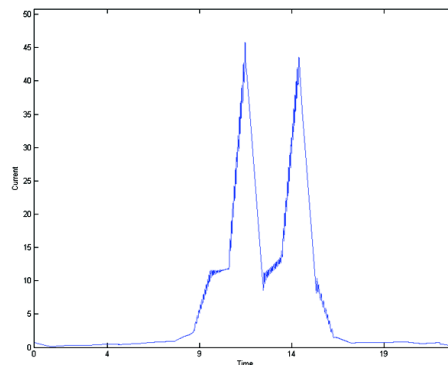

(b) Current (A)

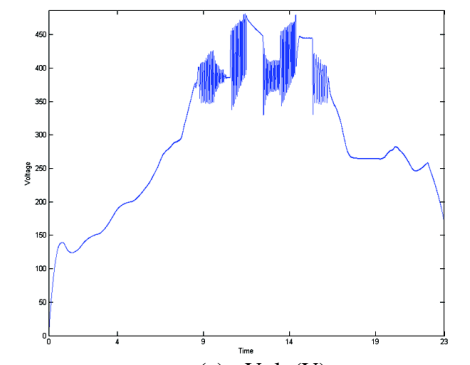

(c) Volt (V)

Using IC algorithm

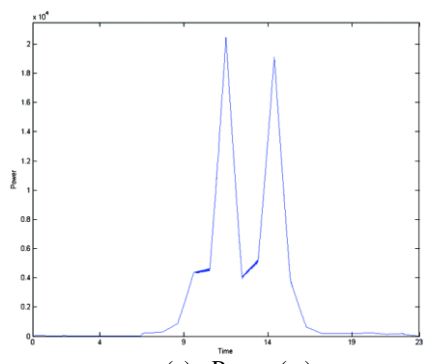

(a) Power (w)

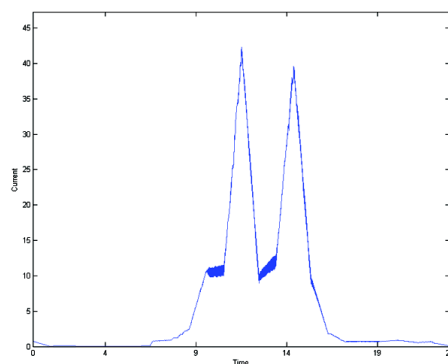

(b) Current (A)

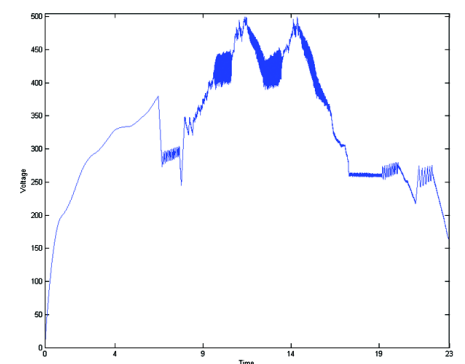

(c) Voltage (V)

Using P&O algorithm

Fig. (6) Dynamic response of PV array during cloudy day using CV, IC and P&O algorithm

Table (5) : PV Performance under different sky conditions

| Sky Condition | Unit | P&O | | IC | |
|-------------------|-------------|-----------------|-----------|-----------------|-----------|
| | | P-P Oscillation | Max Value | P-P Oscillation | Max Value |
| Clear | Voltage (V) | 26 | 510 | 59 | 510 |
| | Current (A) | 13 | 272 | 15 | 273 |
| | Power (Kw) | 0.04 | 140 | 0.03 | 141 |
| Partially Clouded | Voltage (V) | 31 | 481 | 79 | 480 |
| | Current (A) | 2 | 59 | 1.5 | 58.5 |
| | Power (Kw) | 0.05 | 28.5 | 0.08 | 28 |
| Clouded | Voltage (V) | 36 | 479 | 53 | 477 |
| | Current (A) | 1.7 | 42.4 | 2.5 | 42 |
| | Power (Kw) | 0.07 | 22.3 | 0.1 | 22.2 |

Conclusion

This paper presents detailed comparative study between constant voltage technique and the two most popular algorithms for MPPT, namely Perturb & Observe algorithm and Incremental Conductance algorithm. To carry out this study the hourly solar radiation, and temperature were collected for a period of 6 years in Kuwait. The Boost converter with the associated PI controller is used for this comparison. Matlab/ simulink have been used for modelling and simulation of the PV array. The capacity of the simulated PV array is 100 kW under 1000W/m² and 25°C conditions. The comparison of the different MPPT techniques was based on the annual energy generation under different weather conditions. Due to lack of space the average generated energy each month was displayed and compared. The results indicated that the annual generated energy by using P&O and IC algorithms are greater than CV MPPT technique. This is attributed to the fact that, the CV technique did not completely follow the MPP, but instead holding Vref as constant fraction of Voc under any operating condition. The P&O technique provides the greatest annual energy supply for the studied period of 6 years. This is confirmed by their widespread use in commercial implementations. The IC method provided only slightly less annual energy than the P&O. The generated power output of the three methods has the same shape as the solar insulation. The only difference was a small transient due the rapid insulation variation.

In addition, the dynamic response comparison of voltage, current and power output has been traced under different condition of available radiation and temperature. The MPPT controller was tested under a sunny day, and then cloudy and partially cloudy days to calculate the amount of the oscillation in PV operating points. The simulation results indicated that the CV techniques delivered more stable voltage and current signal of the PV array compared to IC and P&O techniques. Underway the fuzzy logic based controller would be considered for further study to enhance the performance of the most effective P&O and IC algorithms to track maximum power point.

References

- [1] Ministry of Electricity and Water, "Statistical year book: Electrical Energy" 36 th Ed. State of Kuwait, 2011.
- [2] A. Mumin, A.Al-Mohaisen, "Greening the Kuwaiti Houses: Studying the Potential of Photovoltaics for Reducing the Electricity Consumption", Global Built Environment Review GBER Journal, Vol. 5 No. 3, pp. 3-10, 2006.
- [3] Photovoltaic devices – part 3: Measurement principles for terrestrial Photovoltaic (PV) solar devices with reference spectral irradiance data, IEC 60904-3-ED. 2.0, 2008.
- [4] T. Nordmann and L. Clavadetscher, "Understanding tempreture effect on pv system performance", Proceedings of 3rd World Conference on Photovoltaic Energy Conversions, vol. 3, May 2003, pp. 2243-2246.
- [5] BP, 230W Photovoltaic module BP 3230T. [Online]. Available: http://www.bp.com/liveassets/bp_internet/solar/bs_solar_usa/STAGING/local_assets/downloads_pdfs/pq/BP3230T_1-10.pdf
- [6] Weidong Xiao, William G. Dunford, Patrick R. Palmer, Antoine Capel, "Regulation of photovoltaic voltage", IEEE Transactions on Industrial Electronics, Vol. 54, No.3, June 2007
- [7] T. Esum and P. Chapman, "Comparison of Photovoltaic array maximum power point tracking techniques," IEEE Transactions on Energy Conversion, Vol. 22, no. 2, Jun. 2007, pp. 439-449.
- [8] T. L. Nguyen and K.-S. Low, "A global maximum power point tracking scheme employing direct search algorithm for Photovoltaic systems," IEEE transactions on Industrial Electronics, vol. 57, no. 10, Oct. 2010, pp. 3456-3467.
- [9] Y. M. Tung, A. P. Hu, N. K. Nair, "Evaluation of Micro Controller Based Maximum Power Point Tracking Methods Using dSPACE Platform," Australian University, Power Engineering Conference 2006.
- [10] Trishan Esum , Pa trick L. Chapman, "Comparison of photovoltaic array maximum power point tracking techniques", IEEE Transactions on energy conversion, Vol. 22, No. 2, June 2007
- [11] F. Liu, Y. Kang, Y.Zhang and S. Duan, "Comparison of P&O and Hill Climbing MPPT Methods for Grid-Connected PV Converter," Industrial Electronics and Applications, 2008. ICIEA 2008. 3rd IEEE Conference, pp. 804 - 807.
- [12] S. Jain, and V. Agarwal, "Comparison of the performance of maximum power point tracking schemes applied to single-stage grid-connected photovoltaic systems," IET Electr. Power Appl., 2007, pp. 753 - 762.
- [13] N. Femia, G. Petrone, G. Spagnuolo, and M. Vitelli, "Optimization of perturb and observe maximum power point trackingmethod," IEEE Trans. Power Electron., vol. 20, no. 4, pp. 963–973, Jul. 2005.
- [14] D. P. Hohmand , M. E. Ropp, "Comparative Study of Maximum Power Point Tracking Algorithms," Progress in Photovoltaic Research and Applications, vol. 11, no. 1, pp. 47–62, 2003

