

Power Quality Issues in Brushless DC Adjustable Speed Drives

M. I. Buzdugan, H. Bălan

¹ Department of Electrical Engineering
Technical University of Cluj-Napoca,
28, Memorandumului str., Cluj-Napoca (Romania),
Phone number: +40 744 560 833, Fax number: +40 264 410 179,
e-mail: mircea.buzdugan@insta.utcluj.ro,
horia.balan@eps.utcluj.ro

Abstract. The paper presents some power quality issues in brushless DC adjustable drives. It is focused on specific tests performed and results obtained for a residential air conditioning system ready to be put on the market (i.e. an air handling unit, a system that conserves a significant amount of energy while maintaining indoor comfort).

In the introductory section, are presented the new smart power modules, based on fast-recovery MOSFET technology as a compact inverter solution, that drive centrifugal fans provided with brushless DC motors. In the second section, the operating principles of air handling units are shortly addressed, along with the detailed test setups and results obtained on harmonics and conducted electromagnetic interference measurements, according to electromagnetic compatibility standards for the air handling unit.

The main conclusion of the paper is that power quality and electromagnetic compatibility issues should be a permanent concern since the early stage of design, in order to save the time and the money involved in applying final retrofitting measures.

Key words

Brushless DC motors (BLDC), Smart Power Modules (SPMs), Fast-recovery MOSFET (FRFET), Air Handling Units (AHU), Harmonics, Electromagnetic interference (EMI).

1. Introduction

Brushless DC motors (BLDC) are considered as high performance motors due to their high reliability, versatility, adequate torque and speed and low maintenance cost.

It is well-known that brushless DC motors are rotating self-synchronous machines provided with a permanent magnet rotor and with known rotor shaft positions for electronic commutation. The advantage of brushless configuration in which the rotor (field) is inside the stator (armature) is simplicity of exiting the phase windings. Due to the absence of brushes, motor length is reduced as well.

Some relative drawbacks of the brushless configuration with respect to the commutator motor are increased complexity in the electronic controller and need for shaft position sensing. But the main disadvantages of the BLDC motor drives nowadays are high cost of the permanent magnet materials, the problem of demagnetization, and limited extended speed, constant power range (compared to a switched reluctance machine) [1].

Main advantages of the BLDC motor drives are high efficiency, low maintenance and long life, low noise, control simplicity, low weight, and compact construction.

Two main classes of PM motor drives have been developed, depending on the shapes of their respective back- electromotive force (EMF) waveforms, sinusoidal or trapezoidal. Brushless DC motors are typically characterized as having a trapezoidal back EMF and are typically driven by rectangular pulse currents which mimic the operation of brush DC motors.

Excitation waveforms for BLDC motors take the form of square-wave current waveforms. The nature of the excitation waveforms permit some important system simplifications compared to sinusoidal PMAC machines. In particular, the resolution requirements for the rotor position sensor are much lower with BLDC motors since only six commutation instants per electrical cycle must be sensed. In addition, the BLDC motor drive only requires a single current sensor in the inverter DC link [2].

However, the simplicity of a BLDC motor drive is responsible for determining an additional source of ripple torque, known as commutation torque, taking the form of torque spikes or dips, generated at each discrete time instant when any of the square-wave current excitation waveforms change levels.

The terms “energy-saving” and “quiet-running” are becoming very important in the world of variable speed motor drives. For low-power motor control, there are increasing demands for compactness, built-in control, and lower overall-cost. An important consideration, in justifying the use of inverters in these applications, is to

optimize the total-cost-performance ratio of the overall drive system. In other words, the systems have to be less noisy, more efficient, smaller and lighter, more advanced in function and more accurate in control with a very low cost.

In order to meet these needs, several companies have developed new series of compact, high-functionality, and high efficiency power semiconductor devices called Smart Power Modules (SPMs). SPM based inverters are nowadays considered an attractive alternative to conventional discrete-based inverters for low power motor drives, specifically for appliances such as air-conditioners, water pumps, etc. [3, 4].

Smart power modules, based on fast-recovery MOSFET (FRFET) technology as a compact inverter solution for small power motor drive applications are composed of six FRFET, and three half-bridge high-voltage integrated circuits (HVICs) for FRFET gate driving. They provide low electromagnetic interference (EMI) characteristics with optimized switch speed. Moreover, since it employs FRFET as a power switch, it has much better ruggedness and larger safe operation area (SOA) than that of an FRFET-based power module or one-chip solution. MCU, DSP can control IGBT/MOSFET by HVIC directly without photo coupler. By adding bootstrap circuit outside of HVIC, high side and low side can be supplied with a signal power source. It can make system miniaturization.

An example, developed by Fairchild Semiconductor, used later in this paper is the Double DIP Package SPM, FSB50550US, having the following features:

- 500V; $R_{DS(on)}=1.4 \Omega(\text{max})$; 3-phase FRFET inverter including high voltage integrated circuit (HVIC)
- 3 divided negative dc-link terminals for inverter current sensing applications
- HVIC for gate driving and under-voltage protection
- 3/5V CMOS/TTL compatible, active-high interface
- Optimized for low electromagnetic interference
- Isolation voltage rating of 1500Vrms for 1min.
- Surface mounted device package
- Moisture Sensitive Level (MSL) 3

Fig. 1 depicts an application example of a recommended MCU interface and bootstrap circuit with parameters for one-leg diagram of the FSB50550US circuit [5].

It is recommended that:

- the bootstrap diode D1 should have soft and fast recovery characteristics with 600-V rating.
- parameters for bootstrap circuit elements are dependent on PWM algorithm; for 15 kHz of switching frequency, typical example of parameters is shown above.
- RC coupling (R_5 and C_5) at each input of motion SPM® and Micom may be used to prevent improper signal due to surge noise.
- bold lines should be short and thick in PCB pattern to have small stray inductance of circuit, which results in the reduction of surge voltage; bypass capacitors such as C_1 , C_2 and C_3 should have good high-frequency characteristics to absorb high-frequency ripple current.

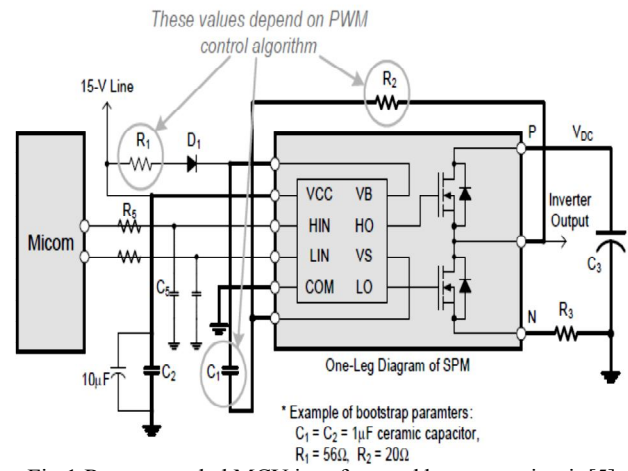

Fig.1 Recommended MCU interface and bootstrap circuit [5]

Unfortunately, high speed semiconductor devices with fast switching capability and the emerging digital era in control and signal processing became the main enemies of electrical power quality. Obviously, power electronics technology offers a plenty of advantages in efficiency and controllability. However, the circuits involved draw nonsinusoidal currents from AC power systems, reacting with system impedances and creating voltage harmonics [6].

The present approach is intended to reiterate the idea that the lack of power quality of power converters, determines necessarily conducted interferences in power lines, which leads to the conclusion that power quality is included in the larger concept of electromagnetic compatibility.

The problem will be approached by a case study of a residential air handling unit, where the centrifugal fans are driven by brushless DC motors and SPMs.

2. Measurements and discussions

A. Air handling units

Energy efficiency of HVAC systems is considered as a vehicle for accomplishing energy savings. Many research efforts related to the modeling and optimization of HVAC systems have been reported in the literature.

A typical air handling unit (AHU) is illustrated in a schematic diagram (Fig. 2), depicting only the two centrifugal fans, the rotary heat exchanger and the air flow directions (see Fig. 3). The supply air is at a specific temperature and flows at a specific rate to meet the heating or cooling load and ensure thermal comfort. Outdoor air mixes with the return air, and the mixed air passes through cooling coils, heating coils, and the supply fan. Chilled water in the cooling coils cools the mixed air, and hot water or steam in the heating coils heats the mixed air to maintain the desired temperature of the supply [7].

Besides, the air handling units are provided with temperature sensors for the return and outside air, fresh air and exhaust air dampers, making sure that there will be airflow only if the fans are running, pressure difference

switches that monitor the airflow in the ducts and generate an alarm in case there is a conflict between the fan run status and airflow status. Moreover air handling units are usually provided with CO₂ and humidity sensors.

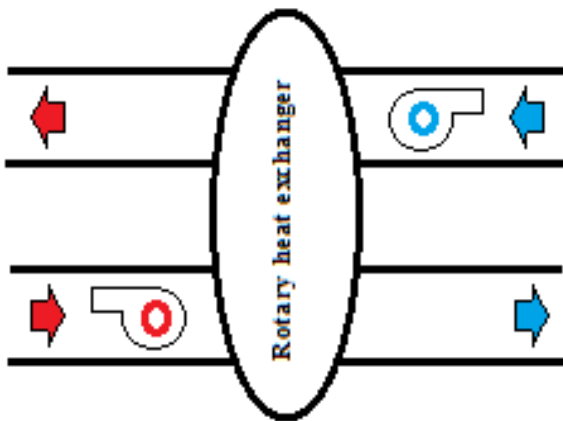

Fig. 2 Schematic diagram of an air handling unit



Fig. 3 Centrifugal fan

Fig. 3 presents the centrifugal fan that equips the air handling unit studied further. The main features of the centrifugal fan, provided with external rotor brushless DC motor are: nominal voltage 230 Vac at 50/60 Hz, maximum current draw 1.35 A, power input 170 W, variable speed drive at maximum speed of 2100 rot⁻¹, maximum air flow of 350 m³/h.

Fig. 4 presents a photo of the electric drive circuit, in which one can easily observe:

- (1) the SPM FSB50550US circuit,
- (2) the input EMI filter, including the common mode choke, the Y2 capacitors MKP63 1 nF/330 Vac and the X2 capacitor 220 nF/310 Vac, typical elements for a standard EMI filter,
- (3) the DC link formed by three bulky capacitors 68 μF/400V,
- (4) the bridge rectifier, GBU 1007,
- (5) the Hall sensor, S41233, sensing the rotor position,

- (6) the controller responsible for the PWM control of the drive,
- (7) the switched power supply of the drive system.

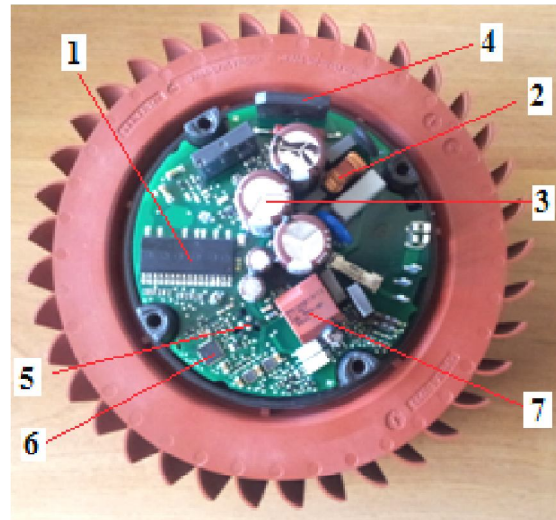

Fig. 5 The driving circuit of the BLDC

B. Harmonic limits check

The centrifugal fan has been tested in conformity with the standard EN 61000-3-2: 2006 (+A1+A2) [8], using the general purpose programmable power source California Instruments 15003iX-CTS, which is a complete IEC AC power test system that covers many of the IEC regulatory test standards involving AC and/or DC powered equipment, providing precise, isolated and low distortion AC power at the user specified frequency and voltage.

The EN 61000-3-2 standard categorizes products in one of four product classes. Using the correct class is important as the harmonic current limits for each class are different. The air handling unit is a Class A equipment. Equipments belonging to Class A are all motor driven equipment, most “domestic” appliances and virtually all 3 phase equipment (<16 A rms per phase). Evaluation of current harmonics is always done using the transitory method so no user selection is provided.

The newer standard allows Class A test to exceed 150% limit and less than or equal to 200% of the applicable limits under the following conditions, which apply all together: the EUT belongs to Class A for harmonics, the excursion beyond 150% of the applicable limits lasts less than 10% of the test observation period or in total 10 min (within the test observation period), whichever is smaller, and the average value of the harmonic current, taken over the entire test observation period, is less than 90% of the applicable limits [9].

The centrifugal fan passed the tests according to the standard EN 61000-3-2. However, for several low order harmonic components (especially for the 9th, 11th, 13th, 15th order components), the values are very close to the limits imposed by the standard (see Fig. 6, where the low order components of the test report are presented). The warnings to be reckoned are colored in yellow, while the virtual ones in green.

California Instruments		Harmonic Limits Check			
	Frequency	Actual	Limit	% of Limit	Compare
1	50.000	0.615			
2	100.000	0.006	1.080	0.556	Pass
3	150.000	0.571	2.300	24.826	Pass
4	200.000	0.008	0.430	1.860	Pass
5	250.000	0.519	1.140	45.526	Pass
6	300.000	0.003	0.300	1.000	Pass
7	350.000	0.451	0.770	58.571	Pass
8	400.000	0.003	0.230	1.304	Pass
9	450.000	0.373	0.400	93.250	Pass
10	500.000	0.003	0.184	1.630	Pass
11	550.000	0.288	0.330	87.273	Pass
12	600.000	0.008	0.153	5.229	Pass
13	650.000	0.205	0.210	97.619	Pass
14	700.000	0.006	0.131	4.580	Pass
15	750.000	0.134	0.150	89.333	Pass
16	800.000	0.003	0.115	2.609	Pass
17	850.000	0.081	0.132	61.364	Pass
18	900.000	0.005	0.102	4.902	Pass
19	950.000	0.054	0.118	45.763	Pass
20	1000.000	0.003	0.092	3.261	Pass

Fig. 6 Harmonic limits test report for the centrifugal fan

The result is quite pessimistic, taking into account that in real conditions, in which the impedance of the system is variable and unknown, the harmonic components of the current drawn by the fan could easily exceed the maximum limits. Even being provided with an input EMI filter, the results were not optimistic, because the air handling unit operates simultaneously with two centrifugal fans, parallel connected and the effect of the two fans THDi's could be cumulative. As it was expected, the equipment failed the harmonic test. The harmonic tests performed on the air handling delivered the results depicted in the test report presented in Fig. 7, for the low order harmonic components.

It can be observed that the presumption made was even too optimistic, because operating in full speed with two motors, the air handling unit failed the test. Note that there are overcome limits until the 23th order harmonic component and the 25th order harmonic is very close to the limit as well.

California Instruments		Harmonic Limits Check			
	Frequency	Actual	Limit	% of Limit	Compare
1	50.000	1.391			
2	100.000	0.006	1.080	0.556	Pass
3	150.000	1.309	2.300	56.913	Pass
4	200.000	0.002	0.430	0.465	Pass
5	250.000	1.184	1.140	103.860	Fail
6	300.000	0.003	0.300	1.000	Pass
7	350.000	1.016	0.770	131.948	Fail
8	400.000	0.001	0.230	0.435	Pass
9	450.000	0.825	0.400	206.250	Fail
10	500.000	0.004	0.184	2.174	Pass
11	550.000	0.625	0.330	189.394	Fail
12	600.000	0.009	0.153	5.882	Pass
13	650.000	0.441	0.210	210.000	Fail
14	700.000	0.004	0.131	3.053	Pass
15	750.000	0.285	0.150	190.000	Fail
16	800.000	0.002	0.115	1.739	Pass
17	850.000	0.178	0.132	134.849	Fail
18	900.000	0.004	0.102	3.922	Pass
19	950.000	0.123	0.118	104.237	Fail
20	1000.000	0.001	0.092	1.087	Pass
21	1050.000	0.109	0.107	101.869	Fail
22	1100.000	0.001	0.084	1.190	Pass
23	1150.000	0.100	0.098	102.041	Fail
24	1200.000	0.002	0.077	2.597	Pass
25	1250.000	0.082	0.090	91.111	Pass

Fig. 7 Harmonic limits test report for the air handling unit

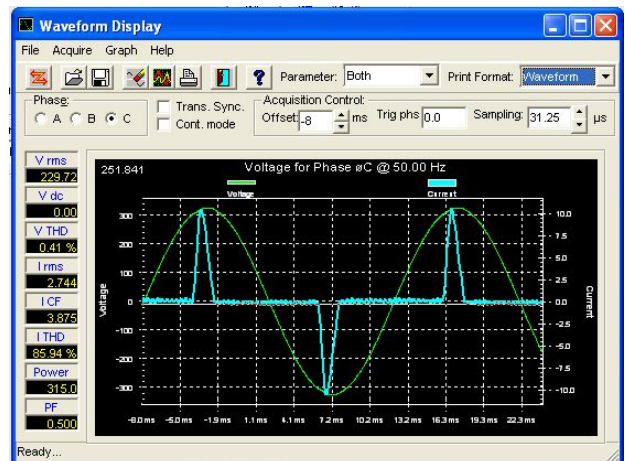

Fig. 9 Supply voltage and current drawn by the AHU

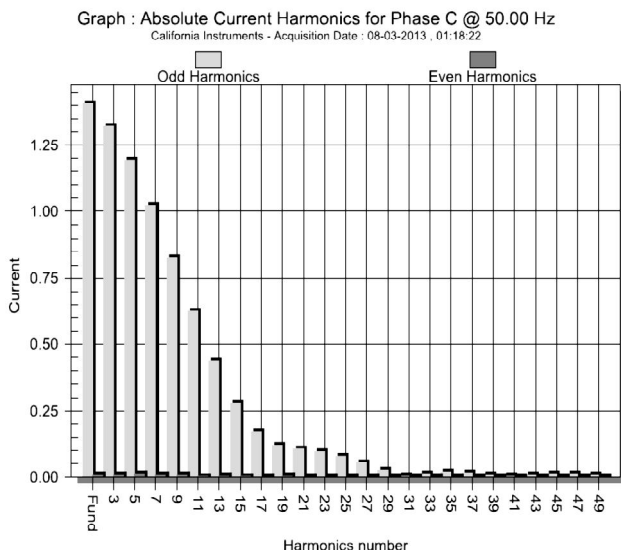

Fig. 8 The FFT chart of the harmonic limits of the AHU

Fig. 8 depicts the FFT chart of the complete test report, until the 50th order harmonic component, while in Fig. 9, is presented the waveform of current drawn by the air handling unit, supplied by a clean 230 Vac sine wave.

The result was an expected one, because the current drawn by the bridge rectifier is generally a discontinuous one and the common mode choke of the EMI filter placed at the input of the board was not sufficient to smooth the current waveform. In situations like that, a line reactor or other countermeasures are compulsory.

C. Conducted electromagnetic interferences check

As it was stated in the introductory section, harmonics determines inevitably conducted interferences. Due to the presence of high harmonics content, it is expected that the

high frequency conducted electromagnetic interference would also appear.

The main purpose of the conducted emission tests consisted in evaluating noise currents that exit the product's AC power cord conductors and the compliance with the standard EN 55014-1:2006 (+A1+A2) [10].

In order to record conducted electromagnetic interference at the mains supply voltage, a line impedance stabilization network (LISN) and a spectrum analyzer have been used.

The first objective of every LISN is to present constant impedance to the product's power cord outlet over the frequency range of the conducted emission test.

Inside the LISN the power lines are terminated with a well-defined impedance network, against each other and against ground, LISN being in principle a filter network.

The two major objectives of the LISN are: to present constant impedance (50 Ω) between the phase conductor and the safety wire and between the neutral conductor and the safety wire and to prevent external conducted noise on the power system net from contaminating the measurement. These two objectives are to be satisfied only over the frequency range of the conducted emission test (150 kHz–30 MHz). Another requirement for the LISN is to allow the 50 Hz (60 Hz) power required for the proper product's operation.

Two identical networks provide the asymmetric noise emission signals of the DUT's power lines L1 and N. The user can choose between the signals, the selected one will be available at the test signal outlet. The stabilization network (simulation for the AC power lines) is arranged in form of a "V".

There is of course no magic changeover at 30MHz. But typical cable lengths tend to resonate above 30 MHz, leading to anomalous conducted measurements, while measurements radiated fields below 30 MHz will of necessity be made in the near field closer to the source giving results that do not necessarily correlate with real situations.

At higher frequencies, mains wiring becomes less efficient as a propagation medium, and the dominant propagation mode becomes radiation from the equipment or wiring in its immediate vicinity.

For measurements with a Spectrum Analyzer/EMC Receiver, the EMC signal is available after having passed a high pass filter.

In order to perform the conducted interference tests, a HM 6050-2 LISN and a HM 5014 spectrum analyzer (both manufactured by HAMEG Instruments) have been used. The schematic setup is presented in Fig. 10.

The conducted interference spectrum conducted in the line wire is depicted in Fig. 11 (in linear scale, where high frequencies are better noticeable) and in Fig. 12 (in

logarithmic scale, where low frequencies are expanded, so better noticeable). The sample (green line), the average value (blue line) and the quasi-peak value (red line) are presented.

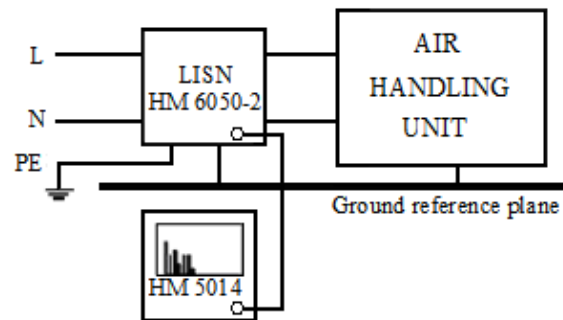

Fig. 10 The schematic test setup for conducted interference

For the neutral wire the spectrum is quite similar, therefore it is not presented here.

One can easily observe that both the average and quasi-peak values of electromagnetic interference exceed the limits imposed by the standard EN 55014-1:2006 (+A1+A2) in the range from 150 kHz up to almost 17 MHz. Especially for the quasi-peak value there is an overcoming of almost 17 dBμV.

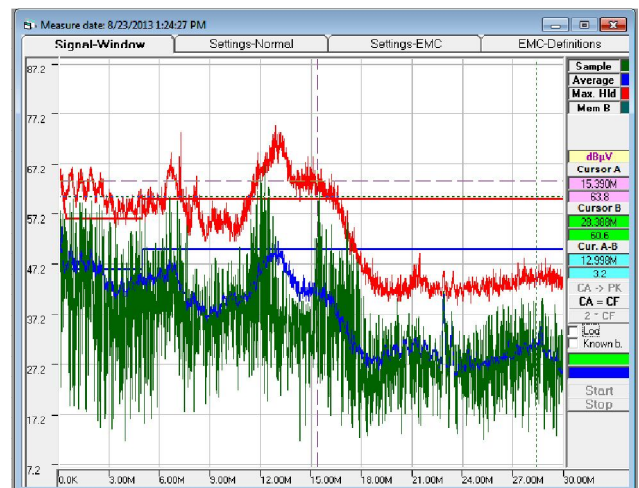

Fig. 11 Conducted interferences of the AHU in linear scale

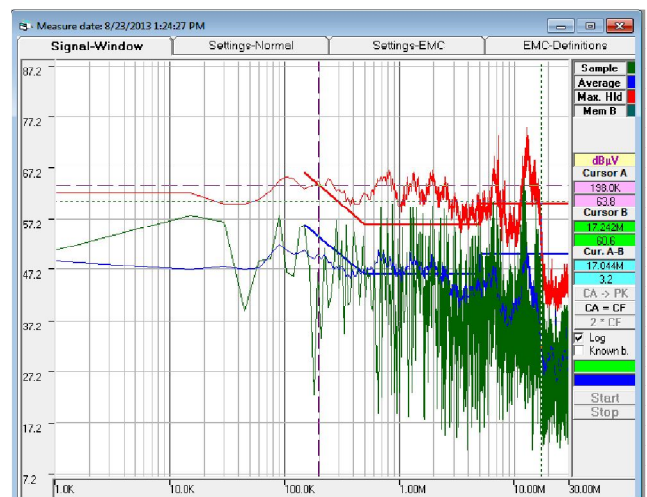

Fig. 12 Conducted interferences of the AHU in logarithmic scale

For the both problems (i.e. harmonics and electromagnetic interference) a combined filtering solution may be adopted (see [6]).

The air handling unit has been also tested for electromagnetic immunity, according to the standard EN 61000-4-13, which defines the immunity test methods and range of recommended basic test levels for electrical and electronic equipment with rated current up to 16 A per phase at disturbance frequencies up to and including 2 kHz (for 50 Hz mains) and 2.4 kHz (for 60 Hz mains) for harmonics and interharmonics on low voltage power networks. The standard establishes a common reference for evaluating the functional immunity of electrical and electronic equipment when subjected to harmonics and inter-harmonics and mains signaling frequencies.

The immunity tests were performed using California Instruments programmable power source CTS 3.0. The equipment was tested to flat top curve test, over-swing curve test, frequency sweep test, individual harmonics and inter-harmonics test, the Meister curve test and passed the immunity tests.

3. Conclusions and Further Works

The main conclusion of this paper is that one can never rely on the fact that every part involved in a product complies with the electromagnetic compatibility standards, because this approach usually does not stand for the whole, as it has been demonstrated above.

Obviously the negative results of harmonic and conducted interference tests make the product unable to be launched on the market and in this final stage of design only retrofitting filtering measures may save it. But, retrofitting measures are costly and time consuming.

No retrofitting measures would be necessary if in the first stage of the design electromagnetic compatibility issues are surveyed.

It is a common place that when switching occurs, so does harmonics and electromagnetic noise, whether it be conducted or radiated.

On the other hand every product must be reasonably insensitive to disturbances that are present on the power grid, in order to ensure its reliable operation.

Basically, in case of switching equipments, filtering measures are essential to meet regulations and, as it could be seen, in certain conditions, an extra filtering cell or replacement of the existing one might be necessary.

It must also be recalled that the EMC problem should represent a continuous concern from the earliest moment of the design stage and the filtering issues have to be considered with much more attention. One always must keep in mind that in design activity, filtering methods shouldn't be considered only as ancillary devices, as they are often treated, but a crucial matter in a successful operation of equipments powered by electrical energy.

The next task that the authors have to fulfill, will be to reconsider the filtering methods for the above presented air handling unit, in order to obtain full compliance with EMC standards.

References

- [1] Emadi, A., *Energy-Efficient Electric Motors*, Marcel Dekker, 2005.
- [2] Kim, I., Nakazawa, N., Kim, S., Park, C., Yu, C., "Compensation of torque ripple in high performance BLDC motor drives", *Control Engineering Practice*, 18, pp. 1166-1172, 2010.
- [3] <http://www.fairchildsemi.com/an/AN/AN-9042.pdf>
- [4] http://www.mitsubishielectric.com/semiconductors/files/manuals/hvic_note_e.pdf
- [5] <http://datasheet.octopart.com/FSB50550US-Fairchild-Semiconductor-datasheet-8734675.pdf>
- [6] Buzdugan, M. I., Bălan, H., "Power Quality versus Electromagnetic Compatibility in Adjustable Speed Drives", *International Conference on Renewable Energies and Power Quality (ICREPQ'13)*, Bilbao, March, 2013.
- [7] Kusiak, A., Zeng Y., Xu G., "Minimizing energy consumption of an air handling unit with a computational intelligence approach", *Energy and Buildings*, 60, pp. 355-363, 2013.
- [8] EN 61000-3-2:2006 (+A1+A2): *Electromagnetic compatibility (EMC) –Part 3-2: Environment – Compatibility levels for low frequency conducted disturbances and signaling in public low-voltage power supply systems.*
- [9] California Instruments, *Compliance Test System User Manual CTS 3.0.*
- [10] EN 55014-1:2006 (+A1+A2): *Electromagnetic compatibility – Requirements for household appliances, electric tools and similar apparatus – Part 1: Emission.*
- [11] EN 61000-4-13:2002+A1:2009: *Electromagnetic compatibility - Testing and measurement techniques. Harmonics and interharmonics including mains signalling at a.c. power port, low frequency immunity tests.*