

A Unit Commitment and Dispatch for a Wind Park Considering Wind Power Forecast

C.F. Moyano¹, J. A. Peças Lopes^{1,2}

1 Instituto de Engenharia de Sistemas e Computadores do Porto, 4200-465 Porto, Portugal

2 Faculdade de Engenharia da Universidade do Porto, 4200-465 Porto, Portugal

Campus da Feup, Dr. Roberto Frias 378, 4200 - 465 Porto

Tel. +351 22 2094000, Fax +351 22 2094050, e-mail: cmoyano@inescporto.pt , jpl@fe.up.pt

Abstract. The present paper describes an optimization strategy, to be adopted at the wind park control level, especially for those with large power output, that allow to define the commitment of the wind turbines and their active and reactive set points following requests from the wind park dispatch centers, assuming that individual wind turbines short term wind power forecasts are known and are expressed as power availability. This approach was also developed with a concern on the minimization of the connection / disconnection of the individual wind generators, for a given time horizon, and takes also into account restrictions in the limits for reactive power generated at the wind turbines.

Key words: Wind Power generation, active and reactive power dispatch, non-linear optimization, mixed integer programming, wind power forecast.

1. Introduction

A hierarchical monitoring and control approach is being developed and adopted in several systems to deal with the needs imposed by the large increase of wind power penetration in power systems. This control approach requires the control of the wind parks output power (active and reactive) through a decentralized dispatch center architecture, where orders are issued from a central dispatch that has the global vision of the system.

Wind Generation Dispatch Centers (acting as Generation Aggregation Agents) will be installed in the Portuguese system, adopting for this purpose a hierarchical control architecture. Having in mind that wind generation can inject power either in the transmission network or in the distribution grids, communication links must be established between the Wind Generation Dispatch Centers and the Transmission System Operator (TSO) or the Distribution System Operators (DSO) [1]. If one assumes also, the participation of wind generation in the market, similar communication links must be established with the market operator. In the Spanish case, all the energy production installations with nominal power up to 10 MW should be associated to a control center, which receives from the

Grid Operator instructions and transmit its instructions to the different installation owners [2]. This legislation also imposes the necessity of wind parks to inform a forecast of the wind power production 30 hours before, with a maximum error of 20%.

Under this scenario, wind generators are expected to be able to control their active and reactive power outputs. Double fed induction wind generators (DFIG) controlled by static converters and variable speed synchronous generators with full electronic grid interface are presently already capable of assuring such individual control capabilities [3].

Regarding DFIG, a great variety of control strategies can be used in the operation of these machines as it can be seen from [4, 5, 6 and 7]. In these works, strategies to control active and reactive power wind park outputs also were proposed. In these researches wind park control models are built-up with a hierarchical modular structure: a central wind park controller sends out reference signals to each local wind turbine controller. Among these works, reference [7] describes an optimization strategy to be adopted at a supervisory wind park control level with the objective of assuring that wind park active and reactive power outputs attend the requests defined by system operators. However it considers wind velocity constant and equal for all the wind turbines and does not consider wind power forecasting errors. In [8] a dispatch module for a wind park is described, assuming however that wind generator's dispatch is performed as a proportional division of operator's request through all the wind turbines.

Wind power forecast needs to be taken into account in the formulation of the optimization strategy. A methodology for short-term wind power forecasts is described in [9]. This approach includes the evaluation of confidence intervals with a confidence level.

The present paper describes an optimization strategy, to be adopted at the wind park control level that allows to define the commitment of the wind turbines and their

active and reactive set points following requests from the wind park dispatch centers, assuming that individual wind turbines short term power forecasts are known and are expressed as power availability according to [9].

2. The optimization formulation

The optimization problem of the wind park management can be solved in a similar way as the one used to manage conventional generation in a power system, through the solution of two interrelated optimization problems. A Unit Commitment problem is solved first, in order to determine the turbines schedule, and the technical dispatch output is performed to determine set points to each turbine in a second step.

For the wind park case, we can assume that X_i , Y_j^i and Z_j^i are respectively binary variables that modeled the status (on/off), the startup and shutdown of each wind turbine. The objective function for this sub-problem is to minimize the number of turbines in operation and status changes, in order to reduce maintenance cost for wind turbines and switching devices.

The Unit Commitment problem can be solved through a mixed integer problem [10], as formulated below.

$$\text{Min} \quad \sum_j^n \sum_{i \in A} (b_j^i X_j^i + c_j^i Y_j^i + d_j^i Z_j^i) \quad (1)$$

s.t.

$$- \sum_{j \in A} (X_j^i P_{g_j}^{\text{Max} S^i}) + P_{\text{Loss}} + P_d^i \leq 0 \quad (2)$$

$$\sum_{j \in A} (X_j^i P_{g_j}^{\text{min} S^i}) - P_{\text{Loss}} - P_d^i \leq 0 \quad (3)$$

$$(X_j^i - X_j^{i-1}) - Y_j^i \leq 0 \quad (4)$$

$$- Y_j^i \leq 0 \quad (5)$$

$$(X_j^{i+1} - X_j^i) - Z_j^i \leq 0 \quad (6)$$

$$- Z_j^i \leq 0 \quad (7)$$

where, b_j^i , c_j^i and d_j^i are cost associated to maintaining the unity active and its cost of startup and shutdown for turbine j at period i . In Wind Power Generation these costs can be considered as constants for an active turbine for a defined interval. Cost for startup and shutdown are considered as related to maintenance costs. $P_{g_j}^{\text{Max} S^i}$ and $P_{g_j}^{\text{min} S^i}$ are respectively the maximum available active power limit of generator j at interval i th, as result of the approach shown in [9], and the minimum active power for each generator j at i th interval, resulting from the minimum technical generation limit of the each turbine. P_d^i is the active power required by the grid operator at the connection bus at i interval. As the power forecast is based in the approach described in [9], that

implies in assuming a confidence interval defined by the operator for each unit commitment.

Coefficients b_j^i , c_j^i and d_j^i can be used to improve different strategies to commit the wind turbines by modifying the relation between coefficients b_j^i and c_j^i and d_j^i in the objective function. On the other hand, when a unit needs to be in an off state, for a determined period, the correspondent b_j^i assumes a high value and the interval of available power assumes a minimum value to avoid its commitment.

Equations (2) and (3) represent the feasibility conditions and equations (4) to (7) represent the operational restrictions assigned to the startup and shutdown for each wind turbine. Losses are considered at this stage as approximations, represented by P_{Loss} in equations (2) and (3), assuming a radial wind park configuration.

The Unit Commitment problem can become unfeasible if the sum of the active power requested by the operator plus the wind park internal losses is greater than the total available wind power or if the sum of the operator request plus the wind park internal losses is lower than the minimum technical limit of one generator. This kind of infeasibility needs to be checked before starting the problem solution.

The wind park dispatch is obtained through the solution of a NLP sub-problem, considering the operational constrains and the minimization of the mismatch between the total wind park generation output (active and reactive) and wind park dispatch center requests. The main difference of the NLP approach presented in this work from the one presented in [7] is that the characteristics of the wind turbine operation are considered into this formulation. Wind turbine reactive power limits are supposed to follow a linear relation with the active power generated as $Q_{g_j}^{\text{Max} S^i} = k^M P_{g_j}^i$ and $Q_{g_j}^{\text{min} S^i} = -k^m P_{g_j}^i$, were k^M and k^m are the parameters of that linear relation.

The objective function adopted consists in the weighted sum of variables α_p^i and α_Q^i that represents the percentage of the non-delivered active and reactive power outputs at interval i (respectively $\alpha^i P_d^i$ and $\alpha^i Q_d^i$) regarding the dispatch center request. Constrains related with the active and reactive power generator limits and voltages in all the nodes are also considered [12]. Other terms can be added to the objective function to model different strategies [7].

The non-linear optimization sub-problem is formulated

for each period i as:

$$\text{Min} \quad \sigma_P \alpha_P^i + \sigma_Q \alpha_Q^i \quad (8)$$

s.t.

$$(1 - \alpha_P^i) \bar{P}_d^i - \bar{P}_g^i + \bar{P}^i(\bar{V}, \bar{\theta}) = \bar{0} \quad (9)$$

$$(1 - \alpha_Q^i) \bar{Q}_d^i - \bar{Q}_C^i - \bar{Q}_g^i + \bar{Q}^i(\bar{V}, \bar{\theta}) = \bar{0} \quad (10)$$

$$- \alpha_P^i \leq 0 \quad (11)$$

$$- \alpha_Q^i \leq 0 \quad (12)$$

$$\bar{P}_g^{\min S^i} \leq \bar{P}_g^i \leq \bar{P}_g^{\max S^i} \quad (13)$$

$$-k^m \bar{P}_g^i \leq \bar{Q}_g^i \leq k^M \bar{P}_g^i \quad (14)$$

$$\bar{V}^{\min i} \leq \bar{V}^i \leq \bar{V}^{\max i} \quad (15)$$

where equations (9) and (10) represent the active and reactive power balance equations in each wind park bus, parameterized by α_P and α_Q as in [11 and 12]. \bar{P}_d and \bar{Q}_d are vectors, with a dimension equal to the number of buses of the wind park, having only one non-zero element representing the active and reactive power requested at the interconnection bus. \bar{P}_g and \bar{Q}_g are vectors that contain the active and reactive power generated at each wind park bus, and $\bar{P}(\bar{V}, \bar{\theta})$ and $\bar{Q}(\bar{V}, \bar{\theta})$ are the active and reactive power balance vectors as function of voltages (\bar{V}) and angles ($\bar{\theta}$) of the wind park buses. \bar{Q}_C represent the capacitors generation present in the wind park.

Limits are imposed in equations (11) and (12) to variables α_P^i and α_Q^i , corresponding $\alpha_P^i = 0$ and $\alpha_Q^i = 0$ to the situation where the requests from the wind park dispatch center are fully carried out. If this limit is not considered, α_P^i and α_Q^i can assume negative values, and the wind park output would be greater than the requested [11].

Wind generator operational limits are considered in equations (13)-(14). In the case of reactive power limits, they are directly included as active power generated functions. Finally, voltage limits (\bar{V}^i) for all the buses are considered in equation (15).

The NLP sub-problem is solved using the predictor-corrector version of the Primal-Dual Non-Linear Interior Points Method, as described in [13].

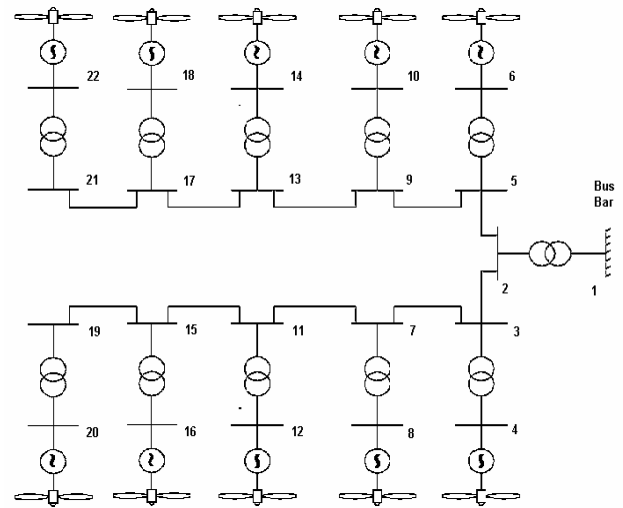

Figure 1: Wind Park schematic

3. Results

Results are presented next to illustrate the capabilities of this approach, using a small wind park with 10 turbines (660 kW nominal capacity) and 21 lines forming two feeders connected to the grid interconnection bus, as shown in figure (1). For each wind generator the reactive power limits are considered as $\pm 40\%$ of active power generated. Voltage limits (V) are assumed to be within the range 0.9-1.1 p.u. No capacitor device was considered for this case.

Considering the approach described in [9], the procedure was tested using 4 time intervals of 15 minutes each. In Table I, maximum estimated generation powers and minimum technical limits for each wind turbine (P^{\max} and P^{\min}) are shown. Estimated generated powers at turbines numbers 22 (period 1), 18 (period 2), 16 (period 3), 12 and 22 (period 4) are zero because the forecasted wind speed is not enough to keep the machine in operation (cut-off zone).

In a first case, the active and reactive power System Operator requests are respectively 2MW and 0.6 MVAR for all periods.

Table II shows the status of the wind turbines for each period. As it can be seen, turbines 16 and 22 are out of service for all periods and turbines 12 and 18 change their status, influenced by the generators in the cut-off zone. The status of the turbines with generation levels under their minimum technical limits was set to zero in the unit commitment step using a large value for coefficients b_j^i in these intervals (1000 in this case).

Meanwhile the others b_j^i coefficients were set equal to 1.

Values of c_j^i and d_j^i in this case were set to 5. The wind park internal active power losses were estimated as 10% of the wind park active power output. Although this may be considered as an overestimation it enables the solution feasibility for the problem.

TABLE I
Forecasted Power in each Turbine (MW)

Bus	Period							
	1		2		3		4	
	P_{max}	P_{min}	P_{max}	P_{min}	P_{max}	P_{min}	P_{max}	P_{min}
4	0.61	0.02	0.25	0.02	0.45	0.02	0.20	0.02
6	0.61	0.02	0.26	0.02	0.54	0.02	0.27	0.02
8	0.65	0.02	0.38	0.02	0.47	0.02	0.64	0.02
10	0.57	0.02	0.31	0.02	0.49	0.02	0.28	0.02
12	0.64	0.02	0.39	0.02	0.58	0.02	-	-
14	0.48	0.02	0.33	0.02	0.65	0.02	0.32	0.02
16	0.52	0.02	0.29	0.02	-	-	0.20	0.02
18	0.66	0.02	-	-	0.51	0.02	0.21	0.02
20	0.46	0.02	0.26	0.02	0.62	0.02	0.20	0.02
22	-	-	0.28	0.02	0.49	0.02	-	-
Total	5.20	0.18	2.73	0.18	4.80	0.18	2.30	0.16

TABLE II
Unit Commitment

Turbine	Periods			
	1	2	3	4
4	1	1	1	1
6	1	1	1	1
8	1	1	1	1
10	1	1	1	1
12	1	1	0	0
14	1	1	1	1
16	0	0	0	0
18	0	0	0	1
20	1	1	1	1
22	0	0	0	0

TABLE III
Turbine dispatch (P(MW),Q(MVAr))

Bus	Periods							
	1		2		3		4	
	P_g	Q_g	P_g	Q_g	P_g	Q_g	P_g	Q_g
4	0.32	0.13	0.25	0.10	0.36	0.14	0.20	0.08
6	0.30	0.11	0.26	0.10	0.34	0.12	0.27	0.11
8	0.28	0.09	0.33	0.10	0.33	0.10	0.57	0.11
10	0.27	0.07	0.31	0.08	0.32	0.09	0.28	0.10
12	0.27	0.06	0.31	0.07	0.00	0.00	0.00	0.00
14	0.31	0.12	0.33	0.13	0.35	0.13	0.21	0.13
18	0.00	0.00	0.00	0.00	0.00	0.00	0.20	0.08
20	0.29	0.10	0.26	0.10	0.33	0.10	0.26	0.08

Results from the dispatch for each period are shown in Table III. Turbines 16 and 22 are not shown because they were not committed. As it can be seen, the active power generated is distributed among all the turbines, and the reactive power produced in generators also maintains the pre-established relation.

Table IV shows the module and angle of the voltages in all the buses of the wind park. Voltage at bus 1 was fixed at 1 p.u., and it can be observed that the internal reactive power production increases the voltage at wind turbines buses. Buses 16 and 22 are not shown because they are not used in all the intervals.

TABLE IV
Turbine dispatch (V, δ)

Bus	Period							
	1		2		3		4	
	V (p.u.)	δ (°)	V (p.u.)	δ (°)	V (p.u.)	δ (°)	V (p.u.)	δ (°)
1	1.00	-2.46	1.00	-2.20	1.00	-2.67	1.00	-2.02
2	1.02	-1.16	1.02	-0.90	1.02	-1.31	1.02	-0.72
3	1.03	-0.18	1.03	-0.18	1.03	-0.18	1.03	-0.18
4	1.03	0.00	1.03	0.00	1.03	0.00	1.03	0.00
5	1.03	-1.18	1.03	-0.93	1.02	-1.33	1.03	-0.74
6	1.03	-0.11	1.03	-0.01	1.03	-0.09	1.03	0.22
7	1.03	-1.20	1.03	-0.94	1.03	-1.33	1.03	-0.76
8	1.03	-0.18	1.04	0.24	1.03	-0.14	1.04	1.30
9	1.03	-1.20	1.03	-0.95	1.03	-1.33	1.03	-0.76
10	1.03	-0.23	1.04	0.15	1.03	-0.16	1.03	0.23
11	1.03	-1.20	1.03	-0.95	1.03	-1.33	1.03	-0.76
12	1.03	-0.24	1.03	0.17	-	-	-	-
13	1.03	-1.18	1.03	-0.92	1.02	-1.33	1.03	-0.74
14	1.03	-0.06	1.03	0.26	1.03	-0.07	1.03	0.40
15	1.03	-1.19	1.03	-0.93	1.02	-1.33	1.03	-0.75
17	1.03	-1.19	1.03	-0.93	1.03	-1.33	1.03	-0.76
18	-	-	-	-	-	-	1.03	-0.02
19	1.03	-1.20	1.03	-0.94	1.03	-1.33	1.03	-0.77
20	1.03	-0.15	1.03	-0.01	1.03	-0.14	1.03	-0.05
21	1.03	-1.20	1.03	-0.94	1.03	-1.33	1.03	-0.77

The importance of the relations between coefficients b_j^i , c_j^i and d_j^i is shown next by analyzing two cases, considering an operator request for each period as shown in Table V and the wind power forecasted shown in Table I.

TABLE V
Operator request

Operator Request	Periods			
	1	2	3	4
P_d (MW)	2.20	1.60	2.80	2.20
Q_d (MVAr)	0.60	0.60	0.48	0.60

In a first case, the coefficients b_j^i are set as 1, except for the cases where the forecasted wind speed is not enough to keep the machine producing (cut-off zone), where large values (equal to 1000) are considered, as in the previous case. c_j^i and d_j^i are set as 0.5, which corresponds to a situation where the minimization of the number of turbines in service has priority over the minimum number of status changes.

Table VI and VII show respectively the unit commitment and the active and reactive power dispatches of the wind turbines for this case.

TABLE VI
Turbine Commitment

Turbine	Periods			
	1	2	3	4
4	0	0	0	1
6	0	1	1	1
8	1	1	1	1
10	0	0	0	1
12	1	1	1	0
14	1	1	1	1
16	0	0	0	1
18	0	0	0	1
20	1	1	1	1
22	0	0	0	0

TABLE VII
Turbine dispatch (P(MW),Q(MVAr))

Bus	Periods							
	1		2		3		4	
	P _g	Q _g	P _g	Q _g	P _g	Q _g	P _g	Q _g
4	0.00	0.00	0.00	0.00	0.00	0.00	0.20	0.08
6	0.00	0.00	0.26	0.10	0.54	0.22	0.27	0.11
8	0.65	0.26	0.36	0.15	0.47	0.12	0.58	0.23
10	0.00	0.00	0.00	0.00	0.00	0.00	0.28	0.01
12	0.64	0.12	0.36	0.15	0.58	0.02	0.00	0.00
14	0.48	0.19	0.33	0.13	0.65	0.26	0.32	0.13
16	0.00	0.00	0.00	0.00	0.00	0.00	0.20	0.08
18	0.00	0.00	0.00	0.00	0.00	0.00	0.21	0.08
20	0.46	0.18	0.26	0.10	0.62	0.07	0.20	0.01
22	0.00	0.00	0.00	0.00	0.00	0.00	0.00	0.00
Total	2,23	0,75	1,57	0,63	2,86	0,69	2,26	0,73

In a second case, for the active power available shown in Table I, the coefficients b_j^i are set as 1, except for the situations where the forecasted wind speed is not enough to keep the machines producing (cut-off zone) which requires using large values (1000) for these coefficients, as in the previous case. c_j^i and d_j^i are set as 50 to illustrate the behavior of this approach in a situation where the minimization of the number of status changes has priority over the number of turbines in service.

Table VIII shows the unit commitment for this case. As can be seen, the main differences of this solution from the previous one consists in switching on turbines 4, 6 and 10 in period 1 and switch on turbines 6 and 10 in period 2 and 3. Turbine 12 remains disconnected for all periods, while in the previous solution was connected at periods 1, 2 and 3.

As expected, in the periods where the forecasted wind speed is such that the turbines are in the cut-off zone, the generators are not committed showing the effectiveness of the proposed algorithm.

Active and reactive power dispatches for all wind turbines can be seen at Table IX. When comparing these results with the previous ones, one can see that the active and reactive powers are more distributed. This fact can be used to improve the control of the wind power output, reducing the dependence of wind park output from the wind power intermittency. Table X shows the full available wind park output active power for the two strategies presented, minimum number of turbines (MNT) and minimum number of status changes (MNC), showing that for the first case there is no possibility of keeping the operator request output if a sudden wind power decrease takes place for periods 1, 2 and 3, because wind turbines are dispatched at its maximum level.

TABLE VIII
Turbine Commitment

Turbine	Periods			
	1	2	3	4
4	1	1	1	1
6	1	1	1	1
8	1	1	1	1
10	1	1	1	1
12	0	0	0	0
14	1	1	1	1
16	0	0	0	1
18	0	0	0	1
20	1	1	1	1
22	0	0	0	0

TABLE IX
Turbine dispatch (P(MW),Q(MVAr))

Bus	Periods							
	1		2		3		4	
	P _g	Q _g	P _g	Q _g	P _g	Q _g	P _g	Q _g
4	0.40	0.16	0.25	0.10	0.45	0.17	0.20	0.08
6	0.38	0.15	0.26	0.10	0.50	0.17	0.27	0.11
8	0.36	0.14	0.28	0.12	0.46	0.10	0.58	0.23
10	0.36	0.02	0.28	0.11	0.47	0.01	0.28	0.01
12	0.00	0.00	0.00	0.00	0.00	0.00	0.00	0.00
14	0.38	0.15	0.28	0.12	0.51	0.17	0.32	0.13
16	0.00	0.00	0.00	0.00	0.00	0.00	0.20	0.08
18	0.00	0.00	0.00	0.00	0.00	0.00	0.21	0.08
20	0.36	0.09	0.26	0.10	0.48	0.05	0.20	0.01
22	0.00	0.00	0.00	0.00	0.00	0.00	0.00	0.00
Total	2,24	0,71	1,61	0,65	2,87	0,67	2,26	0,73

TABLE X
Available Power

Case	Periods			
	1	2	3	4
MNT	2,23	1,62	2,86	2,32
MNC	3,38	1,79	3,22	2,32

Finally, parameters α_p and α_q were analysed. For these cases, operator request of 6 MW and 2 MVAr and 6

MW and 4 MVar are tested considering the available power forecasting presented in Table I for period 1. As the operator request is greater than the maximum capability of wind park at this period, wind park output can not follow the operator request.

In these cases, active and reactive power output is reduced, considering the internal wind park active and reactive power losses. For both operator requests the wind power output are reduced to 4.95 MW and 1.50 MVar. Since the full active power available is dispatched in the two cases, although the parameterization of active and reactive power is independent, the linear relation between active/reactive powers generated imposes this result. Table XI shows the wind turbine dispatch for both operator requests. Values for α_p and α_o are 0.3120 and 0.3451 for the requested 6 MW and 2 MVar, and α_p and α_o are respectively 0.3118 and 0.6241.

TABLE XI
Turbine dispatch

Bus	V (p.u.)	δ (°)	P_g (MW)	Q_g (MVar)
1	1.00	-5.17		
2	1.06	-2.06		
3	1.07	-0.16		
4	1.08	0.00	0.61	0.25
5	1.07	-2.13		
6	1.08	-0.11	0.61	0.24
7	1.07	-2.18		
8	1.08	-0.04	0.65	0.26
9	1.07	-2.21		
10	1.08	-0.35	0.57	0.23
11	1.07	-2.23		
12	1.09	-0.12	0.64	0.24
13	1.06	-2.12		
14	1.08	-0.52	0.48	0.19
15	1.07	-2.17		
16	1.08	-0.45	0.52	0.21
17	1.07	-2.20		
18	1.09	-0.03	0.66	0.26
19	1.07	-2.21		
20	1.08	-0.69	0.46	0.18
21	1.07	-2.21		
22	-	-	-	-
Total generated			5.20	2.07
Wind Park output			4.95	1.50

4. Conclusions

In this paper, an optimization strategy was developed to provide the commitment of wind turbines in a wind park, as well as to identify the active and reactive power set points that result from a local dispatch, applying concepts from classical unit commitment and dispatch and taking into account the characteristics of the turbines

and generation limits obtained from wind power forecasts.

This strategy allows wind parks to follow requests from a System Operator or from a wind park dispatch center, regarding active/reactive power to be generated. Such functionality allows wind park generation to become quite flexible allowing their participation in electricity markets and their response to System Operator requests when a network restriction demands the reduction of generation in a geographical area.

References

- [1] A. Estanqueiro, R. Castro, J.R. Medeiros Pinto, R. Rodrigues, J. Peças Lopes; "How to Prepare a Power System for 12% Wind Energy Penetration: The Portuguese Case Study". Nordic Wind Power Conference, Espoo, Finland, 22-23 May, 2006.
- [2] (2004) Royal Decree 436/2004, Dated March 12th, "Establishing the Methodology to Update and Organize the Legal and Economic Procedures for Electricity Generation Belonging to the Special Regime". [Online]. Available: <http://www.cne.es>
- [3] J. L. Rodriguez-Amenedo et al., "Automatic generation control of a wind farm with variable speed wind turbines," IEEE Trans. Energy Convers., Volume 17, no. 2, pp. 279–284, Jun. 2002.
- [4] J. Wiik, J. O. Gjerde, T. Gjengedal, and M. Gustafsson, "Steady state power system issues when planning large wind farms", Power Engineering Society Winter Meeting, 2002. IEEE Volume 1, 27-31 Jan. 2002 pp:199 - 204 vol.1.
- [5] A. Tapia, G. Tapia, J. X. Ostolaza, J.R. Saenz, R. Criado, J. L. Berasategui, Reactive Power Control of a Wind Farm made up with Doubly Fed Induction Generators (I and II), in Proc. 2001 IEEE Porto Power Tech Conference 10th – 13th September, Porto, Portugal.
- [6] R. G. de Almeida, J. A. Peças Lopes, and J. A. L. Barreiros, "Improving power system dynamic behavior through doubly fed induction machines controlled by static converter using fuzzy control," IEEE Trans. Power Syst., vol. 19, no. 4, pp. 1942–1950, Nov. 2004.
- [7] R.G. de Almeida, E.D. Castronuovo, and J.A. Peças Lopes, Optimum Generation Control in Wind Parks When Carrying Out System Operator Requests. IEEE Transactions on Power Systems, Vol.21, N° 2, May 2006.
- [8] A.D.Hansen, P. Sørensen, F. Iov, F. Blaabjerg, Centralised power control of wind farm with doubly fed induction generators. Renewable Energy 31 (2006) 935-951.
- [9] P. Pinson, G. Kariniotakis, On-line assessment of prediction risk for wind power production forecasts. Wind Energy, Volume 7, N° 2, April/June 2004, 119-132
- [10] M. Carrión; J.M. Arroyo ; A Computationally Efficient Mixed-Integer Linear Formulation for the Thermal Unit Commitment Problem. IEEE Trans. Power Syst. Volume 21, Issue 3, Aug. 2006 Page(s):1371 – 1378.
- [11] C. F. Moyano, R.S. Salgado, Adjusted OPF Solution Using Parameterized Model, Automation and Control Magazine – Brazilian Automation Society, Vol.17 no.2/April, May and June 2006 (in Portuguese).
- [12] S. Granville; J.C.O. Mello; A.C.G. Melo; Application of interior point methods to power flow unsolvability. IEEE Trans. Power Syst., vol 11, no 2, pp.1096-1103, May 1996.
- [13] E. D. Castronuovo, J. M. Campagnolo, and R. Salgado, "New versions of nonlinear interior point methods applied to the optimal power flow," in Proc. IEEE T&D Latin America, São Paulo, Brazil, Apr. 2002.