

# Control Systems of Distributed Generation Modules Aggregated by Cascaded Boost Converters

N. Moaddabi, M. Mahmoodi, G. B. Gharehpetian

Department of Electrical Engineering  
Amirkabir University of Technology  
Tehran (Iran)

Phone/Fax number: +0098 21 64546469, E-mail: [nimamoaddabi@yahoo.com](mailto:nimamoaddabi@yahoo.com), [mishel15\\_fm@yahoo.com](mailto:mishel15_fm@yahoo.com), [grptian@aut.ac.ir](mailto:grptian@aut.ac.ir)

**Abstract.** DC/DC boost converters are usually used to interface the DC output of modern distributed generation resources with the AC system. Distributed generation modules are aggregated to yield the necessary power using either parallel or cascaded architecture. Detailed modeling of an interconnection system incorporating cascaded architecture has not been considered in previous researches. In this paper, suitable control systems for cascaded architecture of power electronic converters in an interconnection system have been studied and modeled in detail. Simulation results indicate the effectiveness of the proposed control systems.

## Key words

Distributed Generation, Interconnection System, Boost Converter, Voltage Source Inverter, Droop Control, Hysteresis Current Control.

## 1. Introduction

The interest in Distributed Generation (DG) systems is increasing due to technical, economical and environmental merits. Modern DG systems include emerging technologies (e.g., fuel cell (FC) and microturbine (MT)) and renewable technologies (e.g., photovoltaic (PV) and wind power (WP)). A DG resource incorporates the prime mover and the primary energy converter.

It must be noted that considering technical and economical issues of available energy conversion systems, the AC power from alternators in MT and WP resources is best applied by rectifying to DC using uncontrolled diode rectifiers [1], [2]. As a result, the primary energy converter in most MT and WP resources includes the alternator and a diode rectifier. The collection of all equipment and functions, taken as a group, used to interconnect a DG resource to the AC utility grid is named as Interconnection System (ICS) [3]. As most DG resources generate either DC or incompatible AC power, the ICS incorporates power electronic conversion systems to interface with standard 50 (or 60) Hz AC utility grid.

The DG active power demand is specified by the command from a local energy manager which considers

various technical and economical criteria, e.g. maximum efficiency operation or cogeneration requirements in FC and MT [4], maximum power point tracking in PV and aerodynamic efficiency optimization in WP systems [1]. The energy manager can also be coordinated with operational and market functions of the AC utility grid by using interfaces with the Distribution Network Operator (DNO) and Market Operator (MO) [5]. Note that a robust power generation system must have an efficient amount of inertial storage to satisfy the initial energy balance as the power demand increases without penalizing the quality of other network quantities [1].

Thus, the inertial storage is required to stabilize the prime mover response to system variations and active power unbalancing. For example, the inertial storage of an AC synchronous generator is provided by the rotor kinetic energy. The DG prime movers may have fast response (e.g., PV and WP prime movers) or slow response (e.g., FC and MT prime movers). However, DG primary energy converters are low inertia or virtually inertia-less. Thus, DG resources are usually combined with energy storage systems (e.g., batteries and capacitors) to improve the dynamic performance of the overall system. The combination of DG and storage systems forms a hybrid system which is usually named as microsource [1], [6]. As a result, the microsource can provide a robust response to changes in the energy manager command. The storage system can be chosen to represent the virtual inertia of the DG system as desired.

The desired amount of inertial storage is stored in a DC or AC link implemented in the ICS of DG systems. In the AC link of ICS, High Frequency AC (HFAC), typically more than 20 kHz has been selected due to easier filtering of higher order harmonics as well as smaller size and lower cost of passive components. However, the HFAC systems have expensive special transformers, complex control structures for AC/AC matrix converters and interaction problems in high frequency converters. As a result, DC link ICS is preferable to HFAC link ICS [7], [8].

## 2. ICS of Aggregated DG Module Systems

As voltage source converters have several advantages over current source converters the DC link is connected to the AC utility grid by a Voltage Source Inverter (VSI) [1], [6], [9]. Considering the inductive termination at the AC side of the VSI, the DC link should be capacitive to avoid a cut set of voltage or current sources during converter switching.

The capacitors in a capacitive DC link are usually named as DC capacitors. In order to use the DC capacitors to provide the required inertial storage for a microsource, the energy manager command should be applied to the VSI control system. In this way, a DG system with capacitive DC link ICS can be considered as a microsource. The DC link voltage must be maintained within specified limits to ensure the stable and continuous operation of the VSI and avoid the complexity of variable DC voltage systems. Following a change in the energy manager command, the active power of the VSI changes and as a result, the DC capacitors release or absorb energy. Thus, the DC link voltage will change. In order to maintain the DC voltage within acceptable limits, a DC voltage control system is required to regulate the DG resource power and to restore the active power balance. Thus, the command from DC voltage controller should be applied to the DG module converter. As a result, the DC voltage controller is implemented for the DG module converter.

Available low power DG modules can be connected electrically to yield the necessary power in high power applications. One approach is to connect each DG system separately to the AC utility grid using independent VSI systems. However, using a single VSI for all DG modules brings the advantages of reduced cost, reduced losses as well as easier design and control of the ICS [4], [8], [10]. Thus, the DG module systems should be aggregated to provide the DC input voltage for the VSI. There are several options to aggregate DG module systems. In order to achieve independent control and fault tolerant operation of DG modules, each DG module should have its own power converter to interface with the DC link. In other words, DG modules are connected separately to the DC link using independent DG module converters. The output terminals of DG module converters at the DC link side can be connected in parallel or series to control the DC input voltage of the VSI. The structure using parallel and series connected DG module converters is known as DC bus and cascaded architecture, respectively.

In the DC bus architecture, circulating currents may occur resulting in increased losses and interference with system operation [8], [10]. Complex design algorithms are required to prevent the possible circulating currents. The control system in cascaded architecture is less complex due to absence of circulating currents. Furthermore, the power switches in series connected DG module converters have

lower voltage ratings and consequently much lower cost than the switches in parallel connected converters [8]. As a result, cascaded architecture is preferable to the DC bus architecture from technical and economical viewpoints. But from reliability point of view, the system unavailability in the case of single converter failure is high for cascade architecture.

Detailed modeling of an interconnection system based on cascaded architecture is not considered in previous researches. In this paper, suitable control systems for converters in cascaded architecture are modeled and studied in details.

Fig. 1 illustrates the ICS of multiple DG modules which has been studied in this paper. DG primary energy converters, i.e. FC stacks, PV arrays or alternators with diode rectifiers in MT and WP resources, generate DC power. Thus, DC/DC boost converters are usually used as DG module converters [1], [2]. Each boost converter has a capacitor at the DC link side.

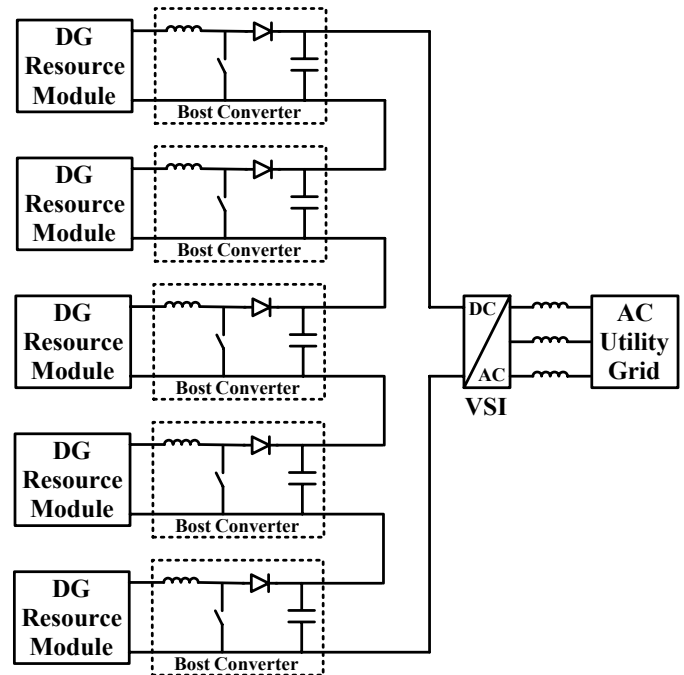

Fig. 1. Interconnection system of cascaded DG modules

As a result, the combination of a DG resource module and its interface boost converter forms a microsource module. In this paper, the microsourses are assumed to have equal ratings. The case of the unequal ratings of the microsourses will be studied in the future works.

## 3. Control Structure of ICS Converters

The converters which control a DC link voltage are named as source converters or regulators [11]. The most commonly used DC voltage control method for regulators

is the droop controller. This control method has the following advantages over other methods:

- It does not need any fast communication systems,
- Its design procedure is simpler and straightforward, and
- It can fulfill the stability requirements easier.

The droop controller provides the set point for either a power controller or a current controller. The power controller is usually based on open loop Pulse Width Modulation (PWM) techniques, such as triangular carrier PWM. The current controller is a closed loop PWM scheme, such as Hysteresis Current Control (HCC), linear PWM, predictive controllers, optimized controllers, neural network and fuzzy logic controller systems.

In comparison to open loop PWM techniques, closed loop PWM schemes have several considerable advantages, such as extremely good dynamics, instantaneous peak current control and prevention of overload and pulse dropping problems [12]. Thus, closed loop PWM schemes are commonly used in power converters. As a result, the droop controller specifies the set point for the current controller.

Note that stability requirements of the DC link should be considered in the design of control systems for regulators. A very simple method for DC capacitor design is presented in [11]. HCC is the simplest closed loop PWM structure and has unconditional large signal stability which is provided by maintaining the current errors within the hysteresis band. Thus, HCC has been selected in this paper. For each boost converter, the droop controller provides the reference current for the HCC system, the HCC scheme controls the current of the boost converter inductor.

The control system of the VSI incorporates a power regulation system to regulate the active and reactive powers of the VSI. The reference active power for the VSI is produced by the energy manager and the reference reactive power for the VSI is specified by its reactive power manager which usually considers operation at unity power factor [9]. There are two methods to regulate the VSI active and reactive powers: average power regulation and instantaneous power regulation [13]. The instantaneous power regulation has much faster response in comparison to average power regulation. Thus, instantaneous power regulation has been used for the VSI in this paper. As a result, the reference currents for the closed loop PWM scheme of the VSI are calculated using instantaneous active and reactive powers concept.

The instantaneous powers can be expressed in either synchronous or stationary reference frame. In Flexible DG (FDG) converters, synchronous frame is applied and the synchronous transformation angle is calculated using the stationary frame transformation [9]. In this paper, only the

stationary frame is used as it is much simpler than the synchronous frame transformation.

As stated before, the energy manager determines the active power of the VSI. The amount of active power that each microsource contributes to the overall VSI active power is determined by the load sharing strategy implemented in the control systems of boost converters. A proper load sharing for multi-converter systems results in equal per-unit loading of regulators [11]. This approach has been used for the load sharing of microsourses in this paper, too. Thus, as the microsourses have equal ratings, the active powers of microsourses should be equal.

#### 4. Control System of Boost Converters

The proposed control system for each boost converter is illustrated in Fig. 2. The DC voltage droop controller specifies the reference current  $i_{dg}^*$  for the HCC scheme. The HCC system regulates the boost converter inductor current,  $i_{dg}$ , within the hysteresis band.

The terminal characteristic or droop characteristic of a regulator is defined at the DC link side of the regulator as follows:

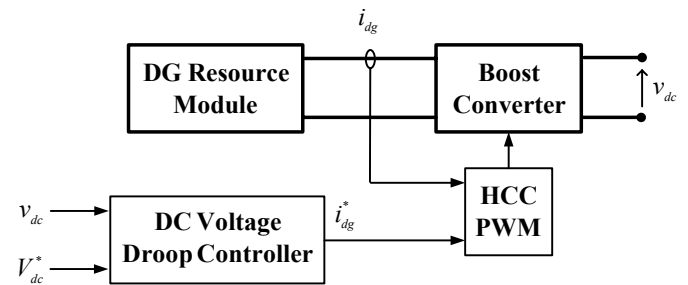

Fig. 2. Proposed control system for each boost converter

$$V_{dc} = V_{dc}^* - R_d I_{dc} \quad (1)$$

where  $V_{dc}$ ,  $I_{dc}$ ,  $V_{dc}^*$  and  $R_d$  are steady state terminal voltage, steady state terminal current, setpoint for terminal voltage and droop coefficient of the boost converter, respectively.

Using (1), the steady state active power  $P_m$  of each boost converter can be obtained as follows:

$$P_m = V_{dc} \cdot \left( \frac{V_{dc}^* - V_{dc}}{R_d} \right) \quad (2)$$

Equation (2) can be used to verify the simulation results for steady state active power of each microsource module. As it can be seen from (2), control system parameters of the boost converters should be identical to

obtain equal loading, i.e. proper load sharing of microsources.

The droop,  $\delta$ , is defined for each boost converter as follows:

$$\delta = \frac{V_{dc}^* - V_{dc}}{V_{dc}^*} \times 100\% \quad (3)$$

The droop coefficient is selected to obtain an acceptable droop at rated power operation. The capacitor of each boost converter is designed to give the droop controller the performance of a Butterworth filter. Thus, the capacitor  $C_{dc}$  for each boost converter is obtained by the following equation [11]:

$$C_{dc} = \frac{2}{R_d \cdot \omega_{LP}} \quad (4)$$

Where  $\omega_{LP}$  is the break-over frequency of the low pass filter used to measure the DC terminal voltage of the boost converter.

The inductor of each boost converter is designed to make its current track the reference current within the hysteresis band. Thus, the inductor  $L$  for each boost converter is obtained by the following equation [14]:

$$L = \frac{4V_{dc}^*}{h \cdot f_{s,max}} \quad (5)$$

Where  $h$  is the hysteresis band and  $f_{s,max}$  is the maximum switching frequency of the boost converter.

## 5. Control System of VSI

The control system of the VSI is shown in Fig. 3. Considering the definition of instantaneous active and reactive powers in the stationary frame ( $\alpha\beta$ -frame), we have [13]:

$$\begin{bmatrix} i_{\alpha}^* \\ i_{\beta}^* \end{bmatrix} = \begin{bmatrix} v_{\alpha} & v_{\beta} \\ -v_{\beta} & v_{\alpha} \end{bmatrix}^{-1} \begin{bmatrix} P^* \\ Q^* \end{bmatrix} \quad (6)$$

Where  $P^*$  and  $Q^*$  are the reference active power and the reference reactive power.  $v_{\alpha}$  and  $v_{\beta}$  indicate the stationary frame voltages obtained from the line-to-line voltages of the AC utility grid.  $i_{\alpha}^*$  and  $i_{\beta}^*$  are the reference currents in the stationary frame which are transformed to three phase reference currents and fed into the HCC scheme.

## 6. Simulation Results

The system shown in Fig. 1 has been modeled and simulated by PSCAD/EMTDC. The rated power of each

microsource module is 10 kW. Thus, the overall system is an aggregate microsource of 50 kW.

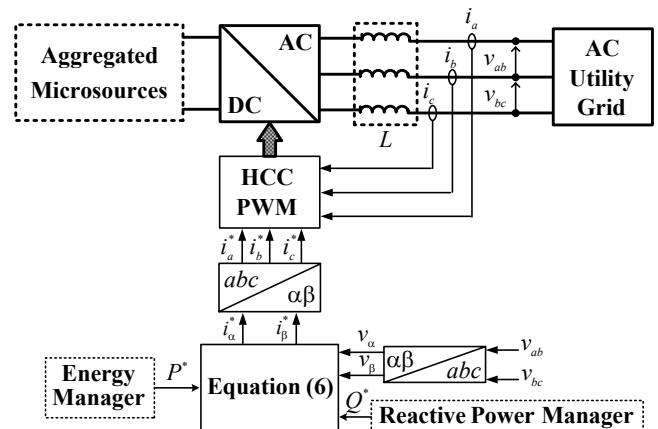

Fig. 3. Proposed control system for VSI

The control system of each boost converter is implemented as shown in Fig. 2. For each boost converter, the DC voltage set point is 150 V, the droop coefficient is designed to obtain a %5 droop at rated power operation. The capacitor at the DC link side and the inductor at the DG module side have been designed using equations (4) and (5). The control system of the VSI is implemented as illustrated in Fig. 3. The HCC scheme of the VSI is designed according to [9]. The reference reactive power of the VSI is equal to zero. Each boost converter assumes to work with %90 its rating power.

The system performance under considerable changes in the energy manager command has been studied here. Fig. 4 shows the VSI active power changes because of changes of power command at  $t=0.15$  s and  $t=0.35$  s.

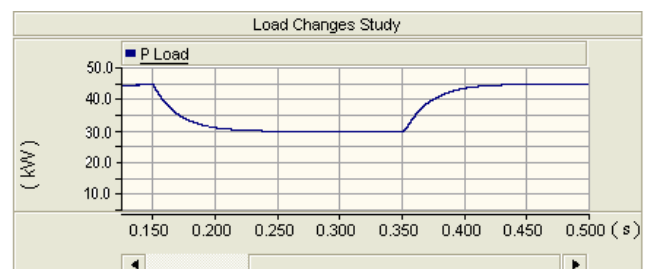

Fig. 4. Active power of VSI

As shown in Fig. 5, the DC terminal voltage of each boost converter is decreased as the VSI active power is increased, and vice versa, but it remains within its specified limits. The instantaneous active powers of the DG modules, as shown in Fig. 6, are equal. These results indicate the effectiveness of the control system, shown in Fig. 2, for boost converters, to provide proper DC link voltage regulation and proper load sharing of microsources.

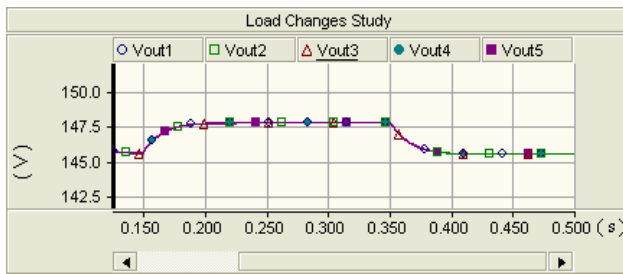

Fig. 5. DC terminal voltages of boost converters

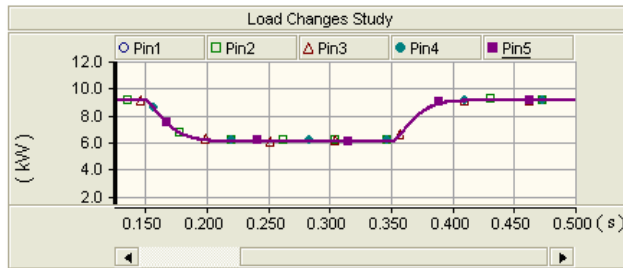

Fig. 6. Active powers of DG modules

The reactive power of the VSI, as shown in Fig. 7, is approximately equal to zero and independent from changes in the energy manager command. This indicates the effectiveness of control system, shown in Fig. 3, for reactive power regulation.

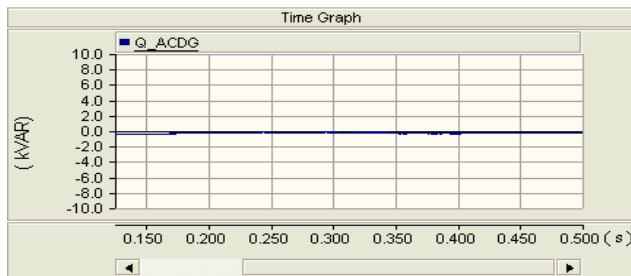

Fig. 7. Reactive power of VSI

In the steady state condition, as shown in Fig. 5 and Fig. 6, we have  $V_{dc}=145.6\text{ kV}$  and  $P_m=9.1\text{ kW}$ . These results can be verified by equation (2), too.

## 6. Conclusion

The cascaded architecture for aggregation of DG modules is preferable to the DC bus architecture from economical and control complexity viewpoints. In this paper, the control system for converters in an ICS based cascaded architecture has been studied. The DG resource converter with the ICS is a DC/DC boost converter. For DC voltage control in each boost converter, droop controller method is used as it simply provides stable operation and proper load sharing of DG modules without requiring fast communication systems. For PWM in each boost converter,

HCC method is used to simplify the fulfillment of interconnection system stability requirements.

For PWM of the VSI, HCC method is used as it is the simplest PWM scheme to have both fast response and insensitivity to system parameters variations required for converters in distribution system applications. An ICS based on cascaded architecture using the proposed control systems is modeled in detail. Simulation results indicate that the proposed control system for cascaded boost converters can provide remarkable DC voltage regulation and proper load sharing.

## References

- [1] CIGRE Technical Brochure on Modeling New Forms of Generation and Storage, November 2000.
- [2] Z. Ye, T. C. Y. Wang, S. Gautam, R. Zhang, "Efficiency comparison for microturbine power conditioning systems", IEEE 34th Annual Power Electronics Specialist Conference, Vol. 4, June 2003.
- [3] IEEE Std 1547.1, IEEE Standard Conformance Test Procedures for Equipment Interconnecting Distributed Resources with Electric Power Systems.
- [4] A. Agustoni, M. Brenna, E. Tironi, "Proposal for a High Quality DC Network with Distributed Generation", CIREN, 17th International Conference on Electricity Distribution, Barcelona, May 2003.
- [5] A. L. Dimeas, N. D. Hatziargyriou, "Operation of a Multiagent System for Microgrid Control", IEEE Transactions on Power Systems, Vol. 20, No. 3, Aug. 2005.
- [6] R. Lasseter, "Dynamic Models for Microturbines and Fuel Cells", IEEE PES Summer Meeting, 2001.
- [7] R. H. Staunton, B. Ozpineci, "Microturbine Power Conversion Technology Review", Oak Ridge National Laboratory, April 2003.
- [8] B. Ozpineci, L. M. Tolbert, D. J. Adams, "Trade Study on Aggregation of multiple 10-kW Solid Oxide Fuel Cell Power Modules", Oak Ridge National Laboratory, Nov. 2004.
- [9] M. I. Marei, E. F. El-Saadany, M. M. A. Salama, "A Novel Control Algorithm for the DG interface to Mitigate Power Quality Problems", IEEE Transactions on Power Delivery, Vol. 19, No. 3, July 2004.
- [10] Y. Ito, Y. Zhongqing, H. Akagi, "DC Micro-grid Based Distribution Power Generation System", The 4-th International Conference on Power Electronics and Motion Control, IPEMC, Aug. 2004.
- [11] P. Karlsson, J. Svensson, "DC Bus Voltage Control for a Distributed Power System", IEEE Transactions on Power Electronics, Vol. 18, No. 6, Nov. 2003.
- [12] M. P. Kazmierkowski, L. Malesani, "Current Control Techniques for Three-Phase Voltage-Source PWM Converters: A Survey", IEEE Transactions on Industrial Electronics, Vol. 45, No. 5, Oct. 1998, pp 691- 703.
- [13] M. Prodanovic, T. C. Green, "Control and Filter Design of Three-Phase Inverters for High Power Quality Grid Connection", IEEE Transactions on Power Electronics, Vol. 18, No. 1, Jan. 2003.
- [14] N. Mohan, T. M. Undeland, and W. P. Robbins, "Power Electronics", New York Wiley, 1989.