



COMILLAS
UNIVERSIDAD PONTIFICIA

ICAI

ICADE

CIHS



MINISTERIO
DE CIENCIA
E INNOVACIÓN



UNIÓN EUROPEA

FONDO EUROPEO DE
DESARROLLO REGIONAL
"Una manera de hacer Europa"



AGENCIA
ESTATAL DE
INVESTIGACIÓN

Islanded Operation of Distribution Grids with High Penetration of Renewable Energy Sources

ICREPQ'22-Vigo, Spain
Luis Rouco
28 July 2021

comillas.edu

Contents

- Introduction
- Field tests
- Protection issues
- Control issues
- Conclusions



Introduction

- Renewable energy sources are being connected not only to transmission but also to distribution grids.
- Medium Voltage (MV) distribution grids are meshed grids that are operated radially.
- Their reliability is determined by their reconfiguration capability.
- However, portions of MV distribution grids can lack supply in case of specific disturbances or abnormal operating conditions.

Introduction

- MV distribution grid

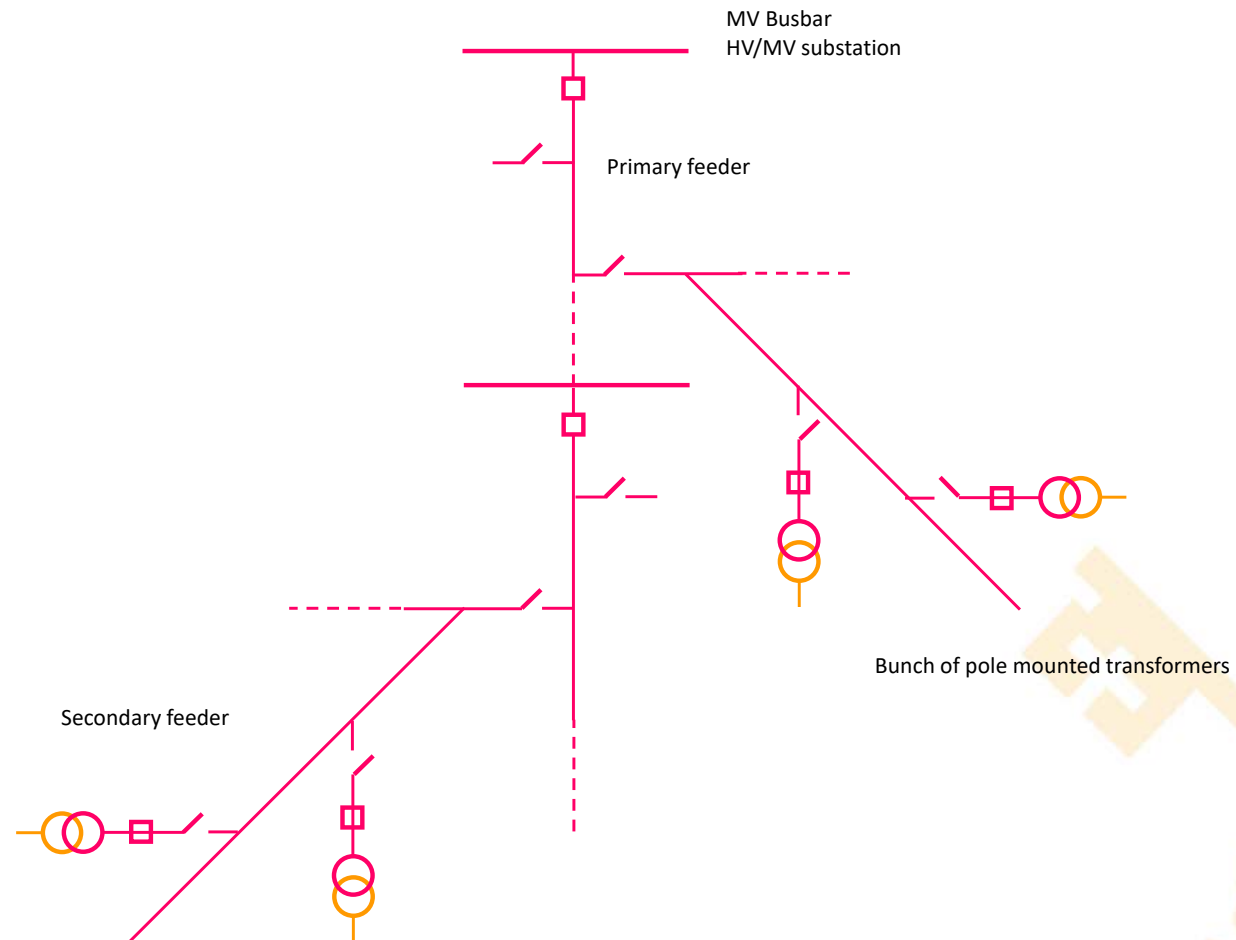



Introduction

- An alternative to the lack of supply in MV distribution grids is the use of the available renewable energy resources.
- The feasibility of the use of renewable energy sources depends on their ability to control both voltage and frequency to guarantee the quality of the electrical supply.
- iDE had found previously unintentional stable islands.

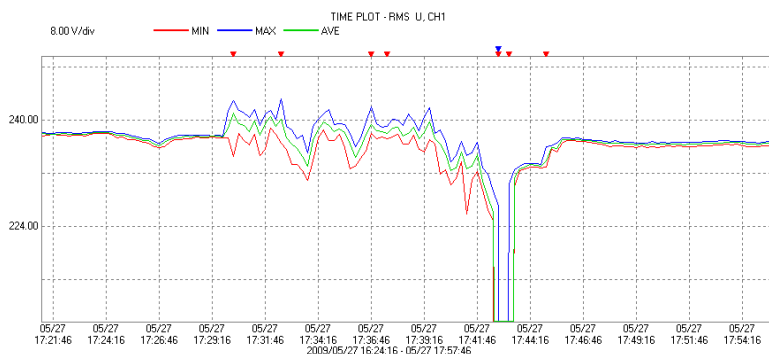

Voltage (max, min, ave)

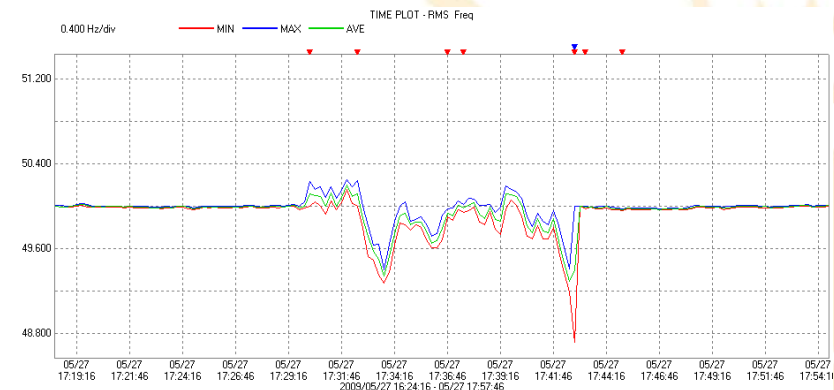

Frequency (max, min, ave)

Introduction

- This contribution reports **real life** of islanded operation of MV distribution grids.
- We will show that such operation **is not feasible** due to the limited control capability of renewable energy sources connected through power electronic converters under grid feeder control scheme.
- In addition, we will show that MV distribution grids can run properly while isolated from the main grid if they incorporate **Battery Energy Storage Systems (BESSs)** under grid former control schemes.
- **Two issues** of the isolated operation of the parallel operation of converters under grid feeder and grid former control schemes will be discussed:
 - Protection (active anti-islanding protection)
 - Control (stability)



Field tests

- **Three islands** have been tested:
 - Belmonte MV power line (Cuenca): PV generation + Load
 - PV plant
 - 18x100 kW inverters (1.8 MW)
 - 16 inverters were connected
 - Fontiveros MV power line (Ávila): PV generation + Load
 - PV plant
 - 10x100 kW inverters (1 MW)
 - 6 inverters were connected
 - Archivel MV power line (Murcia): PV generation + Load + BESS
 - PV plant
 - 15x100 kW inverters (1.5 MW)
 - BESS
 - 1.25 MW / 3.08 MWh

Field tests

- Belmonte MV power line



The PV plant was producing 1.1 MW

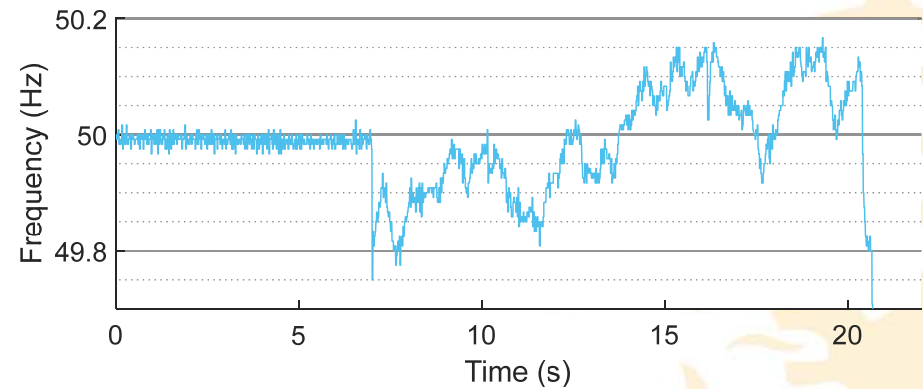
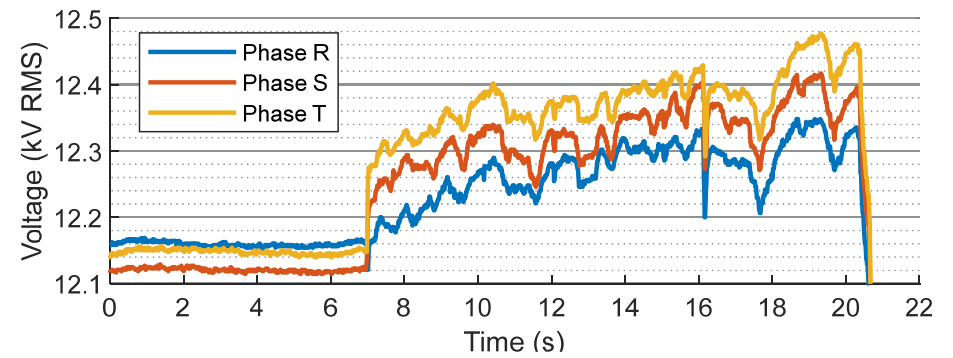

The island remains for 15 seconds

Field tests

- Fontiveros MV power line

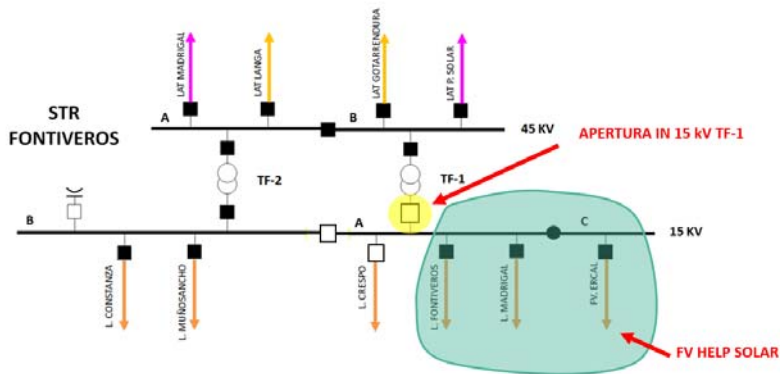

The PV plant was producing 420 kW

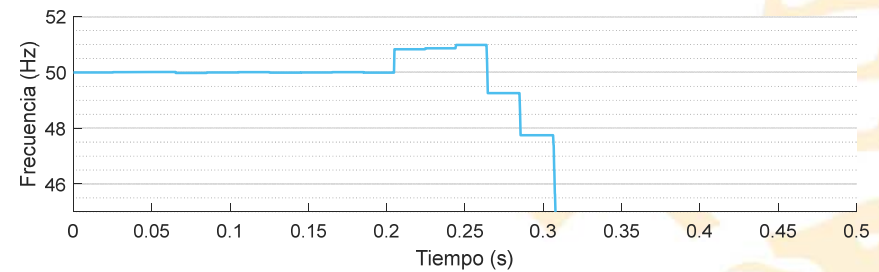
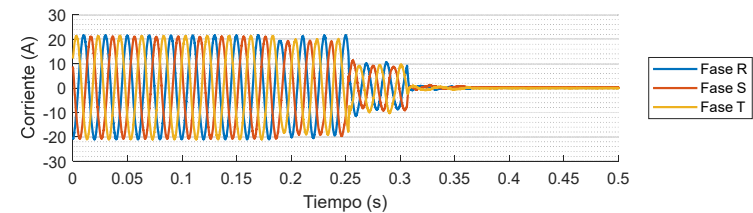
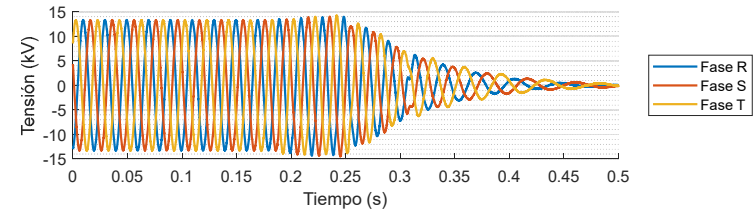

The island remains for 50 milliseconds

Field tests

- Archivel MV power line

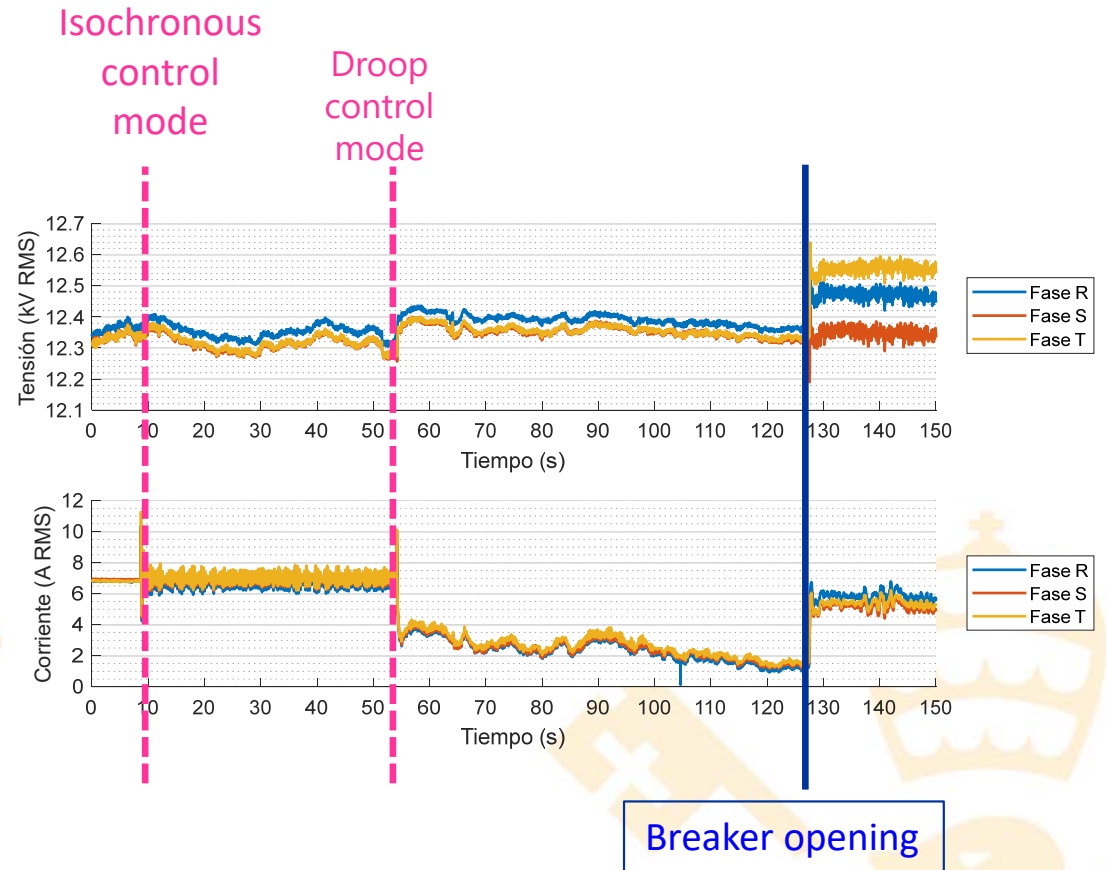
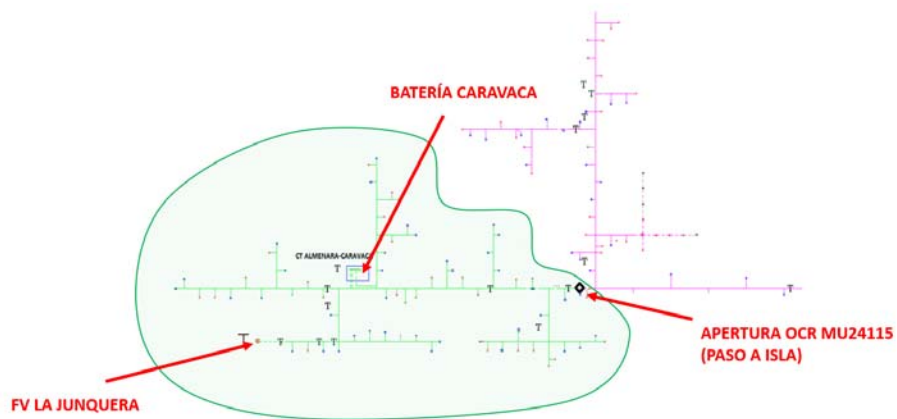

The BESS was producing 50 kW and consuming 250 kVAr

The island remains stable

Protection issues

- Islanded operation of MV distribution grids is not allowed.
- Distributed generation must be equipped with anti-islanding protection (Royal Decrees 1699/2011 y 337/2014).
- Types of anti-islanding protection:
 - Remote
 - Local
 - Pasive
 - Active
 - Hybrid



Protection issues

- Very common **active protection schemes** (developed by Sandia National Laboratories):
 - SFS – Sandia Frequency Shift
 - SVS – Sandia Voltage Shift
- Such protection schemes **perturb the system and monitor** frequency, voltage, or impedance.
- Perturbations are amplified by the positive feedback of a variable.
- As grid feeder converters will work in parallel with grid former converters isolated from the grid, active **anti-island protections may interact with grid former controllers.**



Protection issues

- SFS anti-island protection modifies the reference values of the current components in d- and q-axis according to the frequency variation.
 - The d-axis current component follows the reference.
 - The q-axis current component does not follow the reference which can be interpreted as an acceleration of the voltage space vector.

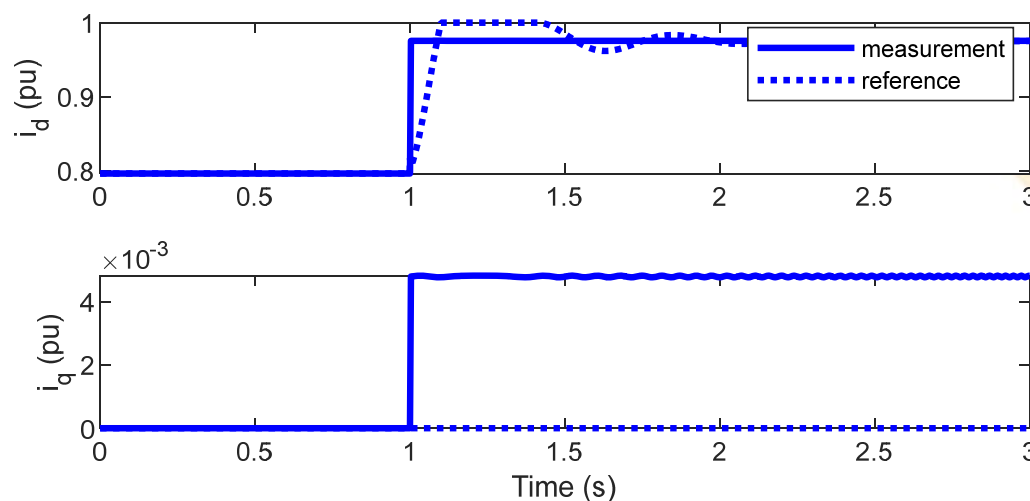

Assume that a grid former converter feeds a RLC load. If a reactive power unbalance occurs, the frequency reaches a new value

$$P_{inv} = \frac{u^2}{r}$$
$$q_{inv} = \frac{u^2}{\omega l} - \omega C u^2 \xrightarrow{q_{inv}=0} \omega = \frac{1}{\sqrt{lc}}$$



Protection issues

- Disconnection from the main grid without and with SFS anti-island protection

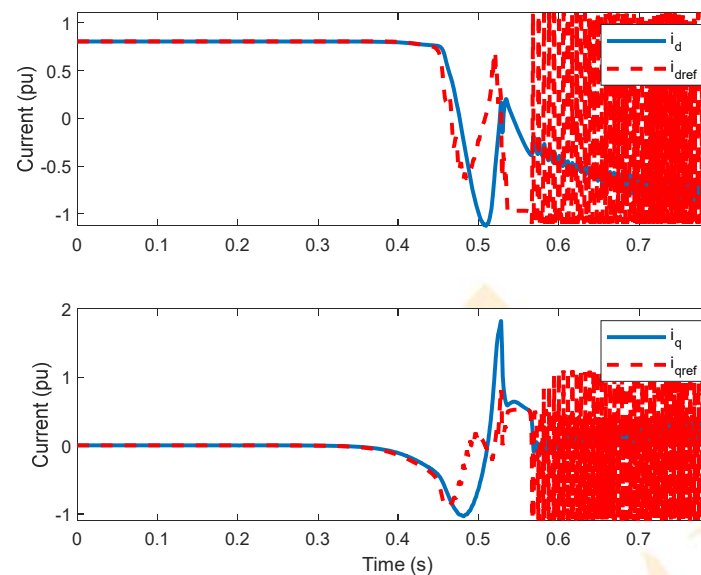
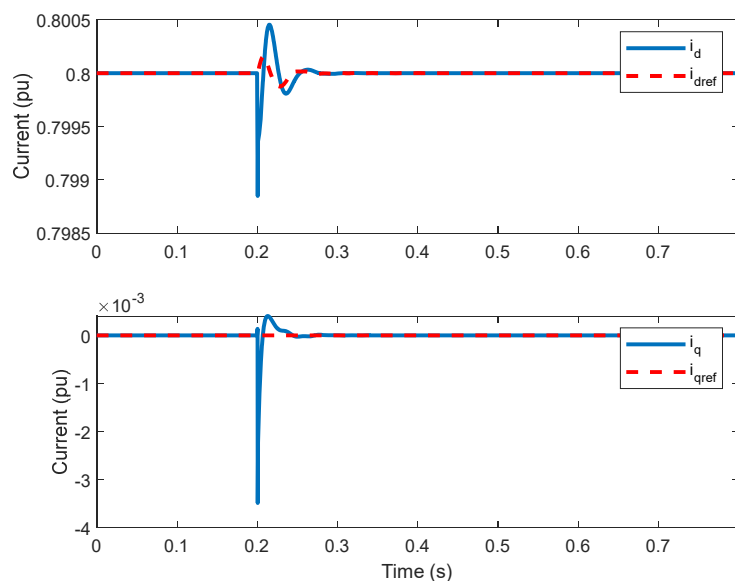



Protection issues

- The impact of a SFS anti-islanding protection is investigated in a case that the BEES + PV plant are disconnected from the grid using a Matlab/Simulink model.

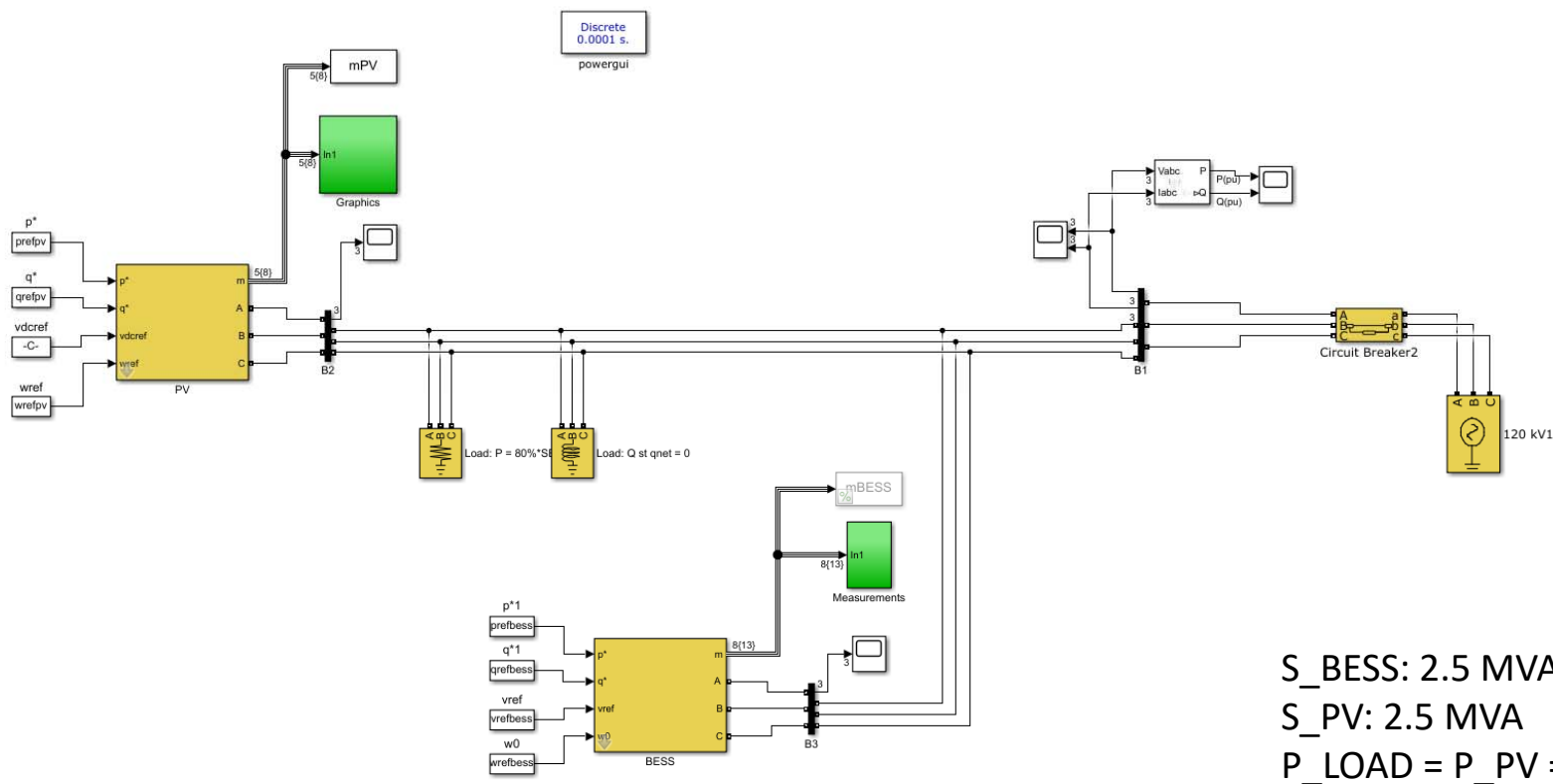

Protection issues

- Impact of the BESS size (from 0.3125 MVA to 2.5 MVA)

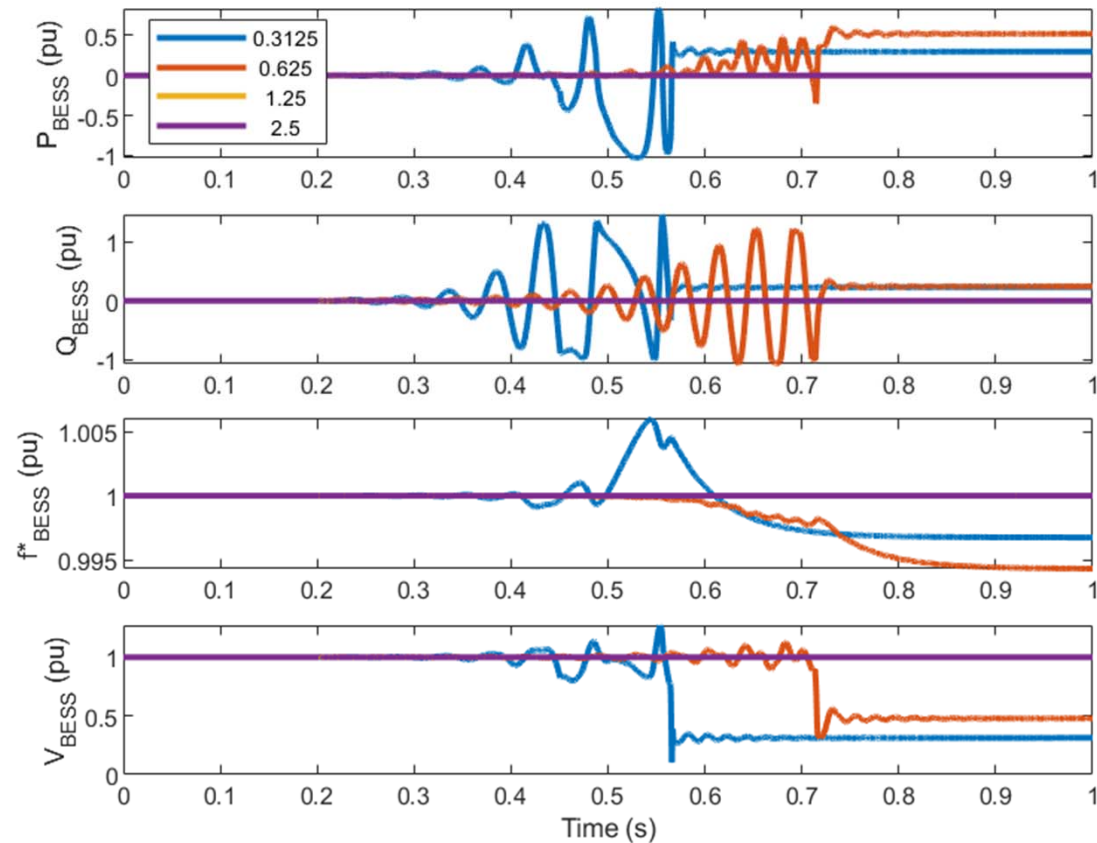

If the BESS is small compared to the PV plant, an adverse interaction occurs

Protection issues

- Sensitivity with respect to the active power droop

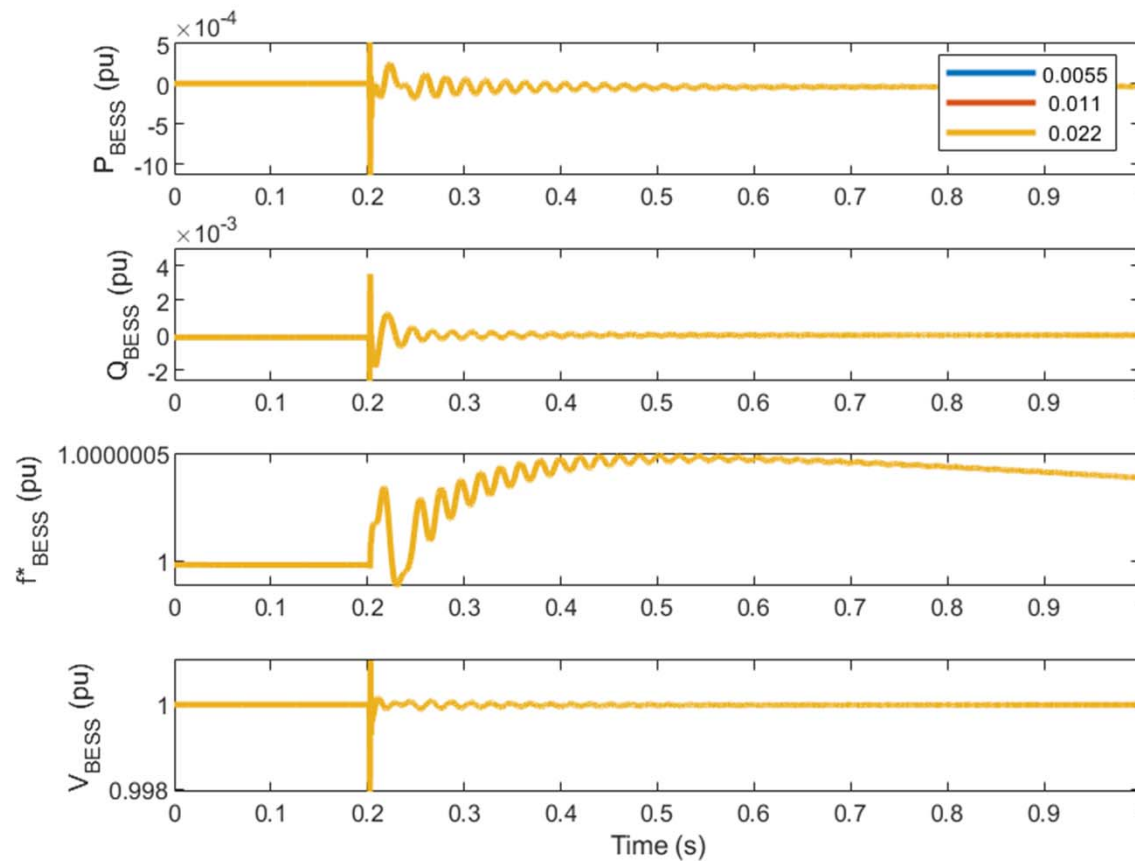

Protection issues

- Sensitivity with respect to the reactive power droop

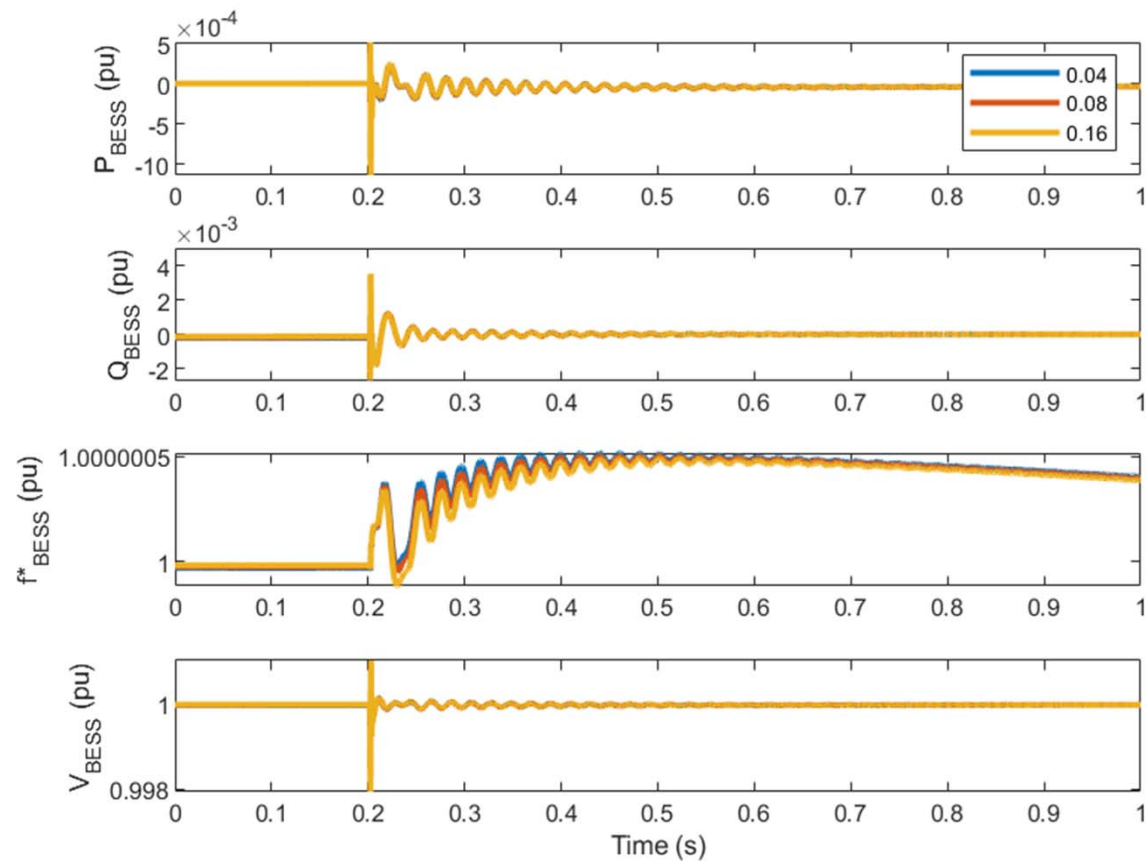



Control issues

- Adverse interactions have been found in the case of two BESSs running in parallel isolated from the main grid under grid former control
 - They actually trip

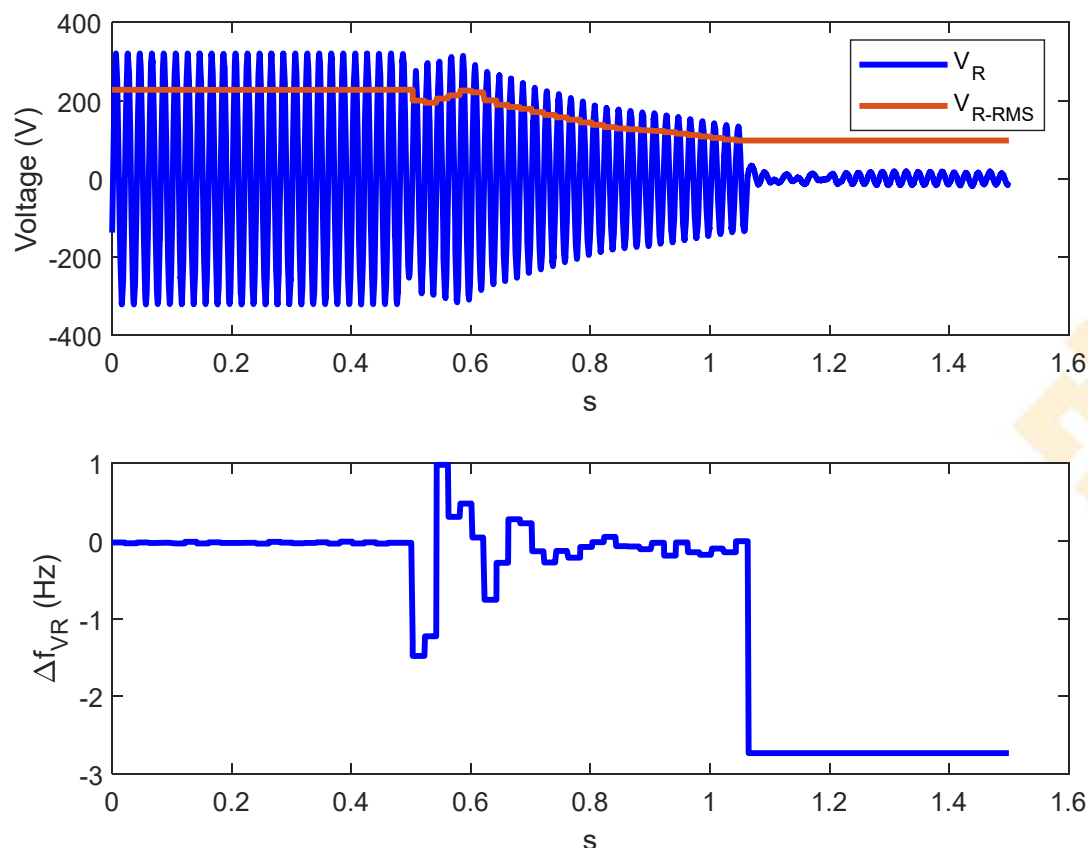



Control issues

- Study method
 - Build a non-linear model
 - Linearize the non-linear model
 - Perform eigenvalue analysis

$$\dot{\mathbf{x}} = \mathbf{F}(\mathbf{x}, \mathbf{u}, \boldsymbol{\eta})$$

$$\mathbf{y} = \mathbf{G}(\mathbf{x}, \mathbf{u}, \boldsymbol{\eta})$$

$$\mathbf{0} = \mathbf{F}(\mathbf{x}_0, \mathbf{u}_0, \boldsymbol{\eta})$$

$$\Delta \dot{\mathbf{x}} = \mathbf{A} \Delta \mathbf{x} + \mathbf{B} \Delta \mathbf{u}$$

$$\Delta \mathbf{y} = \mathbf{C} \Delta \mathbf{x} + \mathbf{D} \Delta \mathbf{u}$$

$$\mathbf{A} \mathbf{v}_i = \mathbf{v}_i \lambda_i$$

$$\mathbf{w}_i^T \mathbf{A} = \lambda_i \mathbf{w}_i^T$$

$$\mathbf{w}_i^T \mathbf{v}_i = 1$$

$$p_{ji} = v_{ji} w_{ij}$$

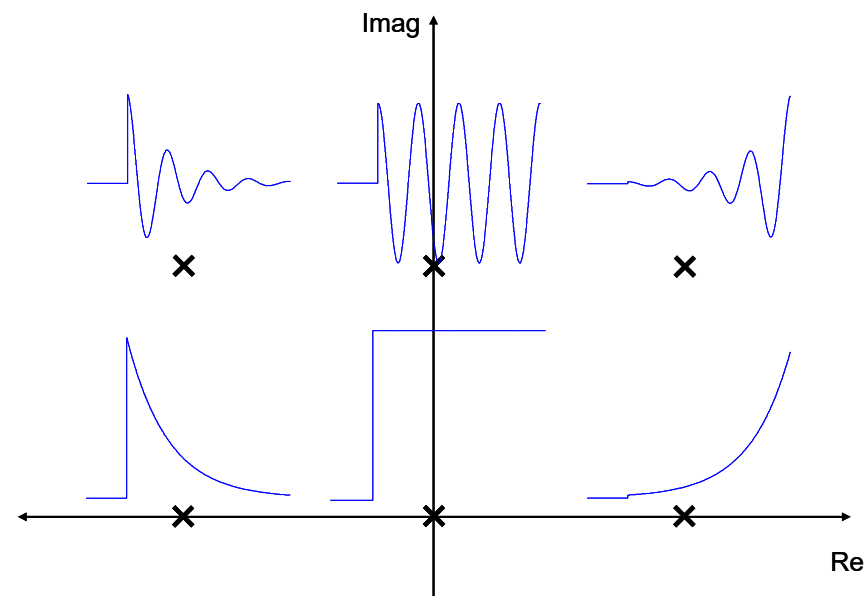

Control issues

- Models

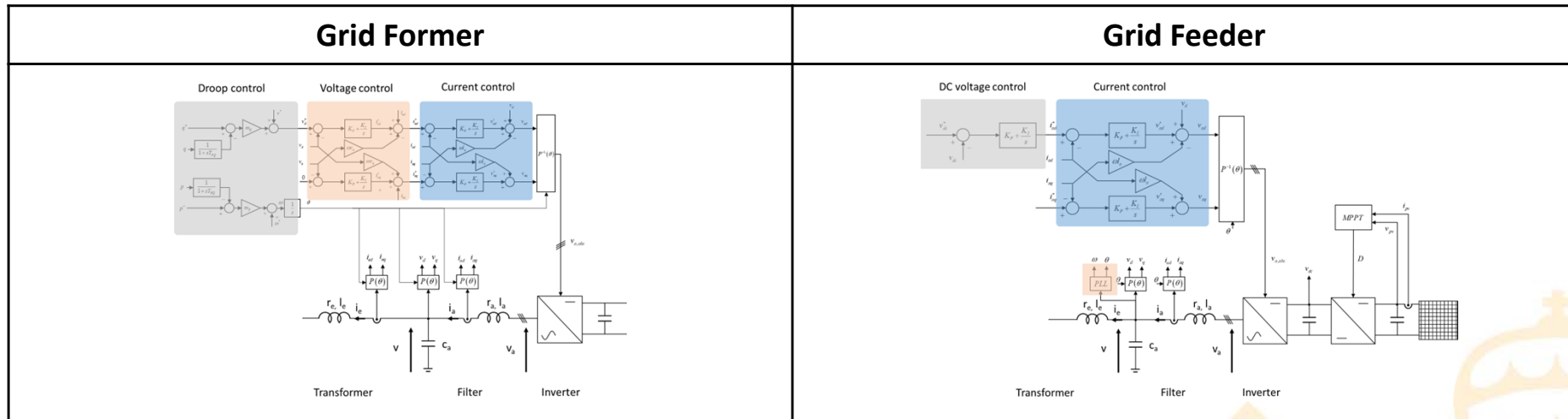

Control issues

- Configuration 1 is stable
- Configuration 2 is also stable
- Configuration 3 is unstable

- Three configurations have been investigated

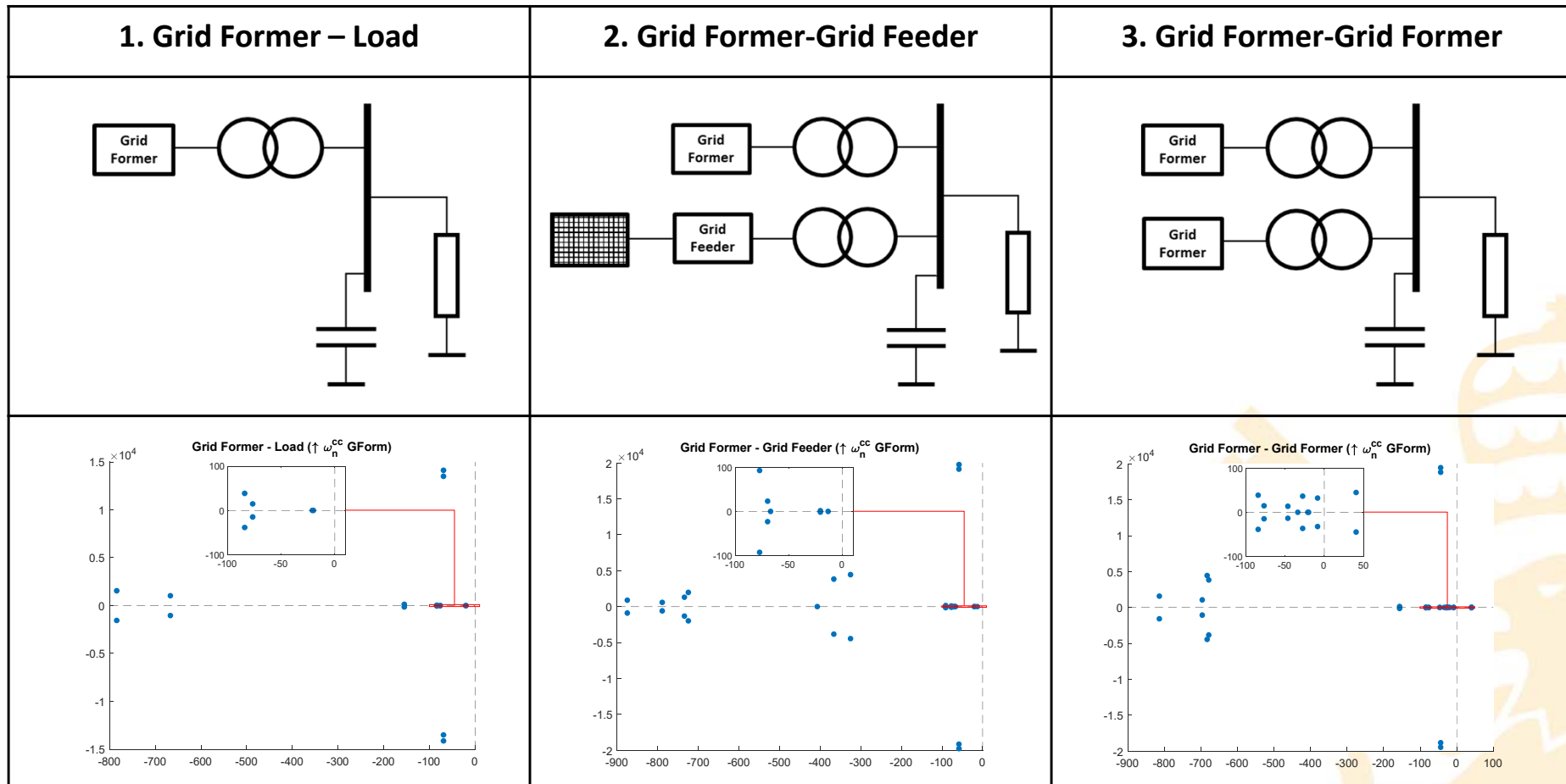



Control issues

- Details of eigenvalue analysis of Grid former-Grid former configuration

| Complex eigenvalues: | | | | | Real eigenvalues: | | | | |
|----------------------|-----------|------------|--------|---------|-------------------|----------|---------------|--------|------|
| N0. | Real | Imag | Damp | Freq | N0. | Real | Time Constant | | |
| 1 | -43.8798 | 19460.9858 | 0.23 | 3097.31 | 25 | -33.7044 | 0.0000 | 100.00 | 0.00 |
| 3 | -43.8847 | 18832.7090 | 0.23 | 2997.32 | 28 | -20.9424 | 0.0000 | 100.00 | 0.00 |
| 5 | -682.8616 | 4443.8653 | 15.19 | 707.26 | 29 | -19.8945 | 0.0000 | 100.00 | 0.00 |
| 7 | -678.4639 | 3835.9551 | 17.42 | 610.51 | 30 | 0.0000 | 0.0000 | NaN | 0.00 |
| 9 | -813.4916 | 1577.0341 | 45.84 | 250.99 | | | | | |
| 11 | -696.2683 | 1059.1631 | 54.93 | 168.57 | | | | | |
| 13 | -156.2623 | 134.2739 | 75.85 | 21.37 | | | | | |
| 15 | -84.1753 | 38.6629 | 90.87 | 6.15 | | | | | |
| 17 | -76.6348 | 14.7346 | 98.20 | 2.35 | | | | | |
| 19 | 40.4718 | 44.6854 | -67.13 | 7.11 | | | | | |
| 21 | -46.3263 | 13.5808 | 95.96 | 2.16 | | | | | |
| 23 | -27.4830 | 36.4789 | 60.17 | 5.81 | | | | | |
| 26 | -8.4847 | 32.1846 | 25.49 | 5.12 | | | | | |

Unstable complex eigenvalue

Control issues

- Details of eigenvalue analysis of Grid former-Grid former configuration

The unstable complex eigenvalue is related to the current controls of both Grid Former systems

| Participation of complex eigenvalues: | | | | | | | | | | | | | | Participation of real eigenvalues: | | | | |
|---------------------------------------|-------|-------|-------|-------|-------|-------|-------|-------|-------|-------|-------|-------|-------|------------------------------------|-------|-------|-------|-------|
| | 1 | 3 | 5 | 7 | 9 | 11 | 13 | 15 | 17 | 19 | 21 | 23 | 26 | | 25 | 28 | 29 | 30 |
| GForm \Psi_{1d} | 0.000 | 0.000 | 0.038 | 0.044 | 0.091 | 0.114 | 0.173 | 0.093 | 0.081 | 0.078 | 0.106 | 0.093 | 0.017 | GForm \Psi_{1d} | 0.006 | 0.000 | 0.000 | 0.000 |
| GForm \Psi_{1q} | 0.000 | 0.000 | 0.038 | 0.044 | 0.091 | 0.114 | 0.174 | 0.078 | 0.083 | 0.076 | 0.106 | 0.092 | 0.020 | GForm \Psi_{1q} | 0.004 | 0.000 | 0.000 | 0.000 |
| GForm \Psi_{od} | 0.118 | 0.118 | 0.119 | 0.118 | 0.005 | 0.004 | 0.006 | 0.001 | 0.001 | 0.021 | 0.004 | 0.009 | 0.006 | GForm \Psi_{od} | 0.001 | 0.000 | 0.000 | 0.000 |
| GForm \Psi_{oq} | 0.118 | 0.118 | 0.119 | 0.118 | 0.005 | 0.004 | 0.006 | 0.001 | 0.000 | 0.021 | 0.004 | 0.009 | 0.006 | GForm \Psi_{oq} | 0.000 | 0.000 | 0.000 | 0.000 |
| GForm v_{od} | 0.005 | 0.005 | 0.121 | 0.118 | 0.086 | 0.051 | 0.263 | 0.548 | 0.466 | 0.021 | 0.033 | 0.034 | 0.003 | GForm v_{od} | 0.043 | 0.003 | 0.000 | 0.000 |
| GForm v_{oq} | 0.005 | 0.005 | 0.121 | 0.118 | 0.086 | 0.051 | 0.265 | 0.441 | 0.575 | 0.025 | 0.071 | 0.043 | 0.005 | GForm v_{oq} | 0.000 | 0.000 | 0.000 | 0.000 |
| GForm P | 0.000 | 0.000 | 0.000 | 0.000 | 0.000 | 0.000 | 0.000 | 0.000 | 0.000 | 0.025 | 0.035 | 0.074 | 0.220 | GForm P | 0.001 | 0.018 | 0.482 | 0.000 |
| GForm Q | 0.000 | 0.000 | 0.000 | 0.000 | 0.000 | 0.000 | 0.001 | 0.010 | 0.011 | 0.027 | 0.051 | 0.069 | 0.012 | GForm Q | 0.213 | 0.475 | 0.018 | 0.000 |
| GForm \theta_{tot} | 0.000 | 0.000 | 0.000 | 0.000 | 0.000 | 0.000 | 0.000 | 0.000 | 0.000 | 0.000 | 0.000 | 0.000 | 0.000 | GForm \theta_{tot} | 0.000 | 0.000 | 0.000 | 1.000 |
| GForm x_{od} | 0.000 | 0.000 | 0.000 | 0.000 | 0.000 | 0.000 | 0.038 | 0.380 | 0.453 | 0.046 | 0.054 | 0.104 | 0.021 | GForm x_{od} | 0.231 | 0.006 | 0.000 | 0.000 |
| GForm x_{oq} | 0.000 | 0.000 | 0.000 | 0.000 | 0.000 | 0.000 | 0.038 | 0.311 | 0.570 | 0.042 | 0.185 | 0.124 | 0.025 | GForm x_{oq} | 0.001 | 0.000 | 0.000 | 0.000 |
| GForm x_{id} | 0.000 | 0.000 | 0.006 | 0.008 | 0.042 | 0.078 | 0.191 | 0.074 | 0.055 | 0.103 | 0.047 | 0.078 | 0.020 | GForm x_{id} | 0.000 | 0.000 | 0.000 | 0.000 |
| GForm x_{iq} | 0.000 | 0.000 | 0.006 | 0.008 | 0.042 | 0.078 | 0.192 | 0.062 | 0.057 | 0.102 | 0.047 | 0.077 | 0.024 | GForm x_{iq} | 0.000 | 0.000 | 0.000 | 0.000 |
| GForm \Psi_{1d} | 0.000 | 0.000 | 0.038 | 0.044 | 0.091 | 0.114 | 0.173 | 0.093 | 0.081 | 0.078 | 0.106 | 0.093 | 0.017 | GForm \Psi_{1d} | 0.006 | 0.000 | 0.000 | 0.000 |
| GForm \Psi_{1q} | 0.000 | 0.000 | 0.038 | 0.044 | 0.091 | 0.114 | 0.174 | 0.078 | 0.083 | 0.076 | 0.106 | 0.092 | 0.020 | GForm \Psi_{1q} | 0.004 | 0.000 | 0.000 | 0.000 |
| GForm \Psi_{od} | 0.118 | 0.118 | 0.119 | 0.118 | 0.005 | 0.004 | 0.006 | 0.001 | 0.001 | 0.021 | 0.004 | 0.009 | 0.006 | GForm \Psi_{od} | 0.001 | 0.000 | 0.000 | 0.000 |
| GForm \Psi_{oq} | 0.118 | 0.118 | 0.119 | 0.118 | 0.005 | 0.004 | 0.006 | 0.001 | 0.000 | 0.021 | 0.004 | 0.009 | 0.006 | GForm \Psi_{oq} | 0.000 | 0.000 | 0.000 | 0.000 |
| GForm v_{od} | 0.005 | 0.005 | 0.121 | 0.118 | 0.086 | 0.051 | 0.263 | 0.548 | 0.466 | 0.021 | 0.033 | 0.034 | 0.003 | GForm v_{od} | 0.043 | 0.003 | 0.000 | 0.000 |
| GForm v_{oq} | 0.005 | 0.005 | 0.121 | 0.118 | 0.086 | 0.051 | 0.265 | 0.441 | 0.575 | 0.025 | 0.071 | 0.043 | 0.005 | GForm v_{oq} | 0.000 | 0.000 | 0.000 | 0.000 |
| GForm P | 0.000 | 0.000 | 0.000 | 0.000 | 0.000 | 0.000 | 0.000 | 0.000 | 0.000 | 0.025 | 0.035 | 0.074 | 0.220 | GForm P | 0.001 | 0.018 | 0.482 | 0.000 |
| GForm Q | 0.000 | 0.000 | 0.000 | 0.000 | 0.000 | 0.000 | 0.001 | 0.010 | 0.011 | 0.027 | 0.051 | 0.069 | 0.012 | GForm Q | 0.213 | 0.475 | 0.018 | 0.000 |
| GForm \theta_{tot} | 0.000 | 0.000 | 0.000 | 0.000 | 0.000 | 0.000 | 0.000 | 0.000 | 0.000 | 0.000 | 0.000 | 0.000 | 0.000 | GForm \theta_{tot} | 0.001 | 0.000 | 0.000 | 0.000 |
| GForm x_{od} | 0.000 | 0.000 | 0.000 | 0.000 | 0.000 | 0.000 | 0.038 | 0.380 | 0.453 | 0.046 | 0.054 | 0.104 | 0.021 | GForm x_{od} | 0.231 | 0.006 | 0.000 | 0.000 |
| GForm x_{oq} | 0.000 | 0.000 | 0.000 | 0.000 | 0.000 | 0.000 | 0.038 | 0.311 | 0.570 | 0.042 | 0.185 | 0.124 | 0.025 | GForm x_{oq} | 0.001 | 0.000 | 0.000 | 0.000 |
| GForm x_{id} | 0.000 | 0.000 | 0.006 | 0.008 | 0.042 | 0.078 | 0.191 | 0.074 | 0.055 | 0.103 | 0.047 | 0.078 | 0.020 | GForm x_{id} | 0.000 | 0.000 | 0.000 | 0.000 |
| GForm x_{iq} | 0.000 | 0.000 | 0.006 | 0.008 | 0.042 | 0.078 | 0.192 | 0.062 | 0.057 | 0.102 | 0.047 | 0.077 | 0.024 | GForm x_{iq} | 0.000 | 0.000 | 0.000 | 0.000 |
| Load \Psi_{1r} | 0.014 | 0.014 | 0.000 | 0.000 | 0.156 | 0.133 | 0.174 | 0.025 | 0.017 | 0.000 | 0.000 | 0.000 | 0.000 | Load \Psi_{1r} | 0.000 | 0.001 | 0.000 | 0.000 |
| Load \Psi_{1i} | 0.014 | 0.014 | 0.000 | 0.000 | 0.156 | 0.133 | 0.175 | 0.024 | 0.015 | 0.000 | 0.000 | 0.000 | 0.000 | Load \Psi_{1i} | 0.000 | 0.001 | 0.000 | 0.000 |
| Netw v_{br} | 0.239 | 0.239 | 0.000 | 0.000 | 0.012 | 0.012 | 0.001 | 0.000 | 0.000 | 0.000 | 0.000 | 0.000 | 0.000 | Netw v_{br} | 0.000 | 0.000 | 0.000 | 0.000 |
| Netw v_{bi} | 0.239 | 0.239 | 0.000 | 0.000 | 0.012 | 0.012 | 0.001 | 0.000 | 0.000 | 0.000 | 0.000 | 0.000 | 0.000 | Netw v_{bi} | 0.000 | 0.000 | 0.000 | 0.000 |



Conclusions

- Real life tests have shown that **stable operation** **islanded** operation of MV distribution grids **is not feasible** due to the limited control capability of renewable energy sources connected through power electronic converters under grid feeder control scheme.
- In addition, they have proved that **MV distribution grids can run properly while isolated** from the main grid **if they incorporate BEES**.
- **Anti-islanding protections** of grid feeding converters **may interact with grid former converters** of BEESs if their rating is low.
- **Unstabilities may occur** in the case of devices under grid former control scheme running in parallel while isolated from the main grid.

Acknowledgments

- The work reported in this contribution was carried out under RETOS de Colaboración project ALOIS with grant number RTC-2017-6296-3 funded by MCIU/AEI/FEDER, UE.
- iDE Team:
 - Abel Santamaría, Asier Barroso, Francisco Javier Ballesteros, Eugenio de Gabriel, Pedro Martínez, and Ohiane Barreiro.
- IIT Team:
 - Lukas Sigrist, Candela Utrilla, Luis de la Barba, and Luis Rouco.